

星光传动官方网站



星光传动官方微信

### 广东星光传动股份有限公司

GUANGDONG STARSHINE DRIVE CO., LTD.

广东省佛山市三水区白坭镇汇金工业城 10 号  
ADD: NO.10,Huijin Industrial park, Baini Town,Sanshui district,Foshan,Guangdong,China

HTTP://www.xgcd.cn 中文域名: 星光传动 . 网址  
TEL: 400 850 5665 FAX:0757-66639837/838  
E-MAIL:xg-sales@xgcd.cn

## YE3电机/变频电机选型手册

SELECTING MANUAL FOR YE3 MOTOR  
VARIABLE FREQUENCY MOTOR

动静之间 · 唯简不凡



广东星光传动股份有限公司前身是一家创建于1965年的国有军工企业——国营星光工模具厂，公司在追求全体员工物质和精神双重幸福的同时，以行业领先的减变速机应用技术，驱动全球工业革新为使命，建设觉悟型组织，成为服务全球的幸福企业为愿景。

公司技术力量雄厚，现有员工420余人，其中工程技术人员40多名，和各种先进的加工制造和检测设备，依托省级工程技术研究中心、减速机产品试验室和现代化研发和生产基地，为高端减变速机产品的行业应用开发和服务提供了良好的发展基础。

公司主导产品有：NCJ系列齿轮减速机、R/S/K/F系列高精度齿轮减速机、RV系列蜗杆减速器、SNKG系列齿轮减速机、JWB-X系列机械无级变速器、B/JXJ系列摆线针轮减速机、SCK系列准双曲面齿轮减速机等七大系列产品可供选用，公司广泛服务于陶瓷、纺织、玻璃、木工、高压开关、食品饮料、包装印刷、仓储物流、起重运输等装备制造和应用行业，专为中高端用户提供专业的产品和服务。产品畅销国内，远销欧美、中东、东南亚等20多个国家和地区。

在未来的发展中，星光传动聚焦客户需求，提供有竞争力的传动解决方案，持续为客户创造价值，打造高端制造业和终端用户“替代进口、升级换代”的首选品牌！

动静之间，唯简不凡；携手同行，星光灿烂！

Guangdong Starshine Drive Co.,Ltd, the predecessor was a state-owned military mould enterprise which established in 1965. While pursuing the spiritual and material happiness of all employees, With the Mission" with industry-leading reduction and transmission technology to drive industrial renewal" and Vision" Build a conscious organization, become a happy enterprise serving the world".

Starshine has a strong technical force with over 400 employees at present, including over 40 engineering technicians, and kinds of advanced processing machines and testing equipment. Thanks to the Provincial Engineering Technology Research Center, the speed reducer product laboratory, the modern R&D and production base, that make Starshine has a good foundation to develop and service for high-end speed reducers.

Our main products include: helical geared motor, worm gearboxes, planetary gearboxes, speed variators, cycloidal gearboxes, helical-hypoid gearboxes, which widely used in ceramic industry, glass industry, woodworking machinery, high voltage switch, food & beverage, packaging & printing, Storage & logistics, hoisting & transportation facilities...etc, Starshine technically provide the professional product & service for the medium and high-end customers, and our gearboxes are best-selling in both domestic and abroad market, such as Europe, North America, South America, Middle East, South Asia, Southeast Asia, Africa...etc more than 20 countries and regions.

In future, Starshine will hold the business creed of "serving customer, diligence & simplicity, self-criticism, innovation, honesty, teamwork", and take "authenticity, altruism, openness, innovation, responsibility, collaboration" as core values. Focus on customers' requirements and provide them the competitive transmission solution and create value for them constantly, and create a preferred brand of replacing import products and upgrading continuously for the end users.

Between Dynamic and Static, Simple is Extraordinary, let's go forward hand in hand and make a brilliant future!

# 目录 CONTENT

国之星光

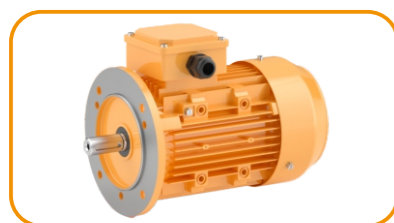

YE3系列高效电机 ..... 01-09  
YE3 Series High-Efficiency Motor

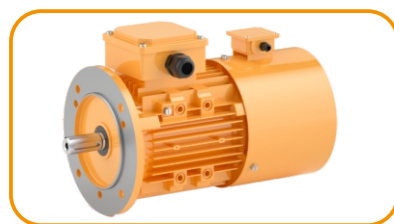

YVF系列变频调速电机 ..... 10-17  
YVF series frequency variable speed motor



**YE3系列高效电机**  
YE3 SERIES HIGH-EFFICIENCY MOTOR

## ● 主要特点 Main Characteristics

YE3系列高效电机63-200是一款可以满足国内外客户用途的鼠笼型低压三相异步电动机，具有效率高、节能、外形美观、性能好、振动小、噪音低、寿命长、可靠性高、维护方便、起动转矩大等优点。能效等级符合GB18613-2020中三级能效等级要求，同时满足IEC60034-30中IE3能效等级要求，安装尺寸和功率等级完全符合IEC/DIN标准。采用F级绝缘，防护等级为IP55，冷却方式IC411。

YE3 Series High-Efficiency motor 63-200 is a kind of squirrel cage low-voltage 3-phase asynchronous motor, a basic series for general use. YE3 series motors have the advantages of high efficiency, energy-saving, good performance, low noise, small vibration, high reliability, convenient maintenance, and big breakaway torque. Efficiency can meet the Level 3 requirement of GB18613-2020 and IEC60034-30 IE3 requirements, mounting dimensions, and rated power are completed to conform to IEC/DIN standards. It employs class F insulation, Ip55 protection and IC411 cooling method.

## ● 适用条件 Operating Condition

环境温度：-15-40℃

海拔：不超过1000米

工作方式：S1连续制

电压：380V (根据需要可设计为400V、415V、220/440V、220-240/380-420V等)

频率：50HZ (或根据需要为60HZ)

绝缘等级：F

防护等级：IP55

冷却方式：IC411

接法：3KW 及以下为“Y”接法，4KW 及以上为“Δ”接法

可选附件：编码器、防雨风罩、热敏电阻、热保护器等

Ambient temperature: -15-40℃

Altitude: not exceeding 1000m above sea level

Duty Type: S1(Continuous)

Voltage: 380V

Frequency: 50HZ(60HZ Special Request)

Insulation Class: Class F, the temperature rise not exceed 80C

Protection class: IP55

Cooling method: IC411

Connetion: Star-connection for 3kW and below, Delta connection for 4kW and above

Accessory Option: encoder, waterproof fan cover, thermistor, thermal protector

## ● 电机结构 Motor Structure

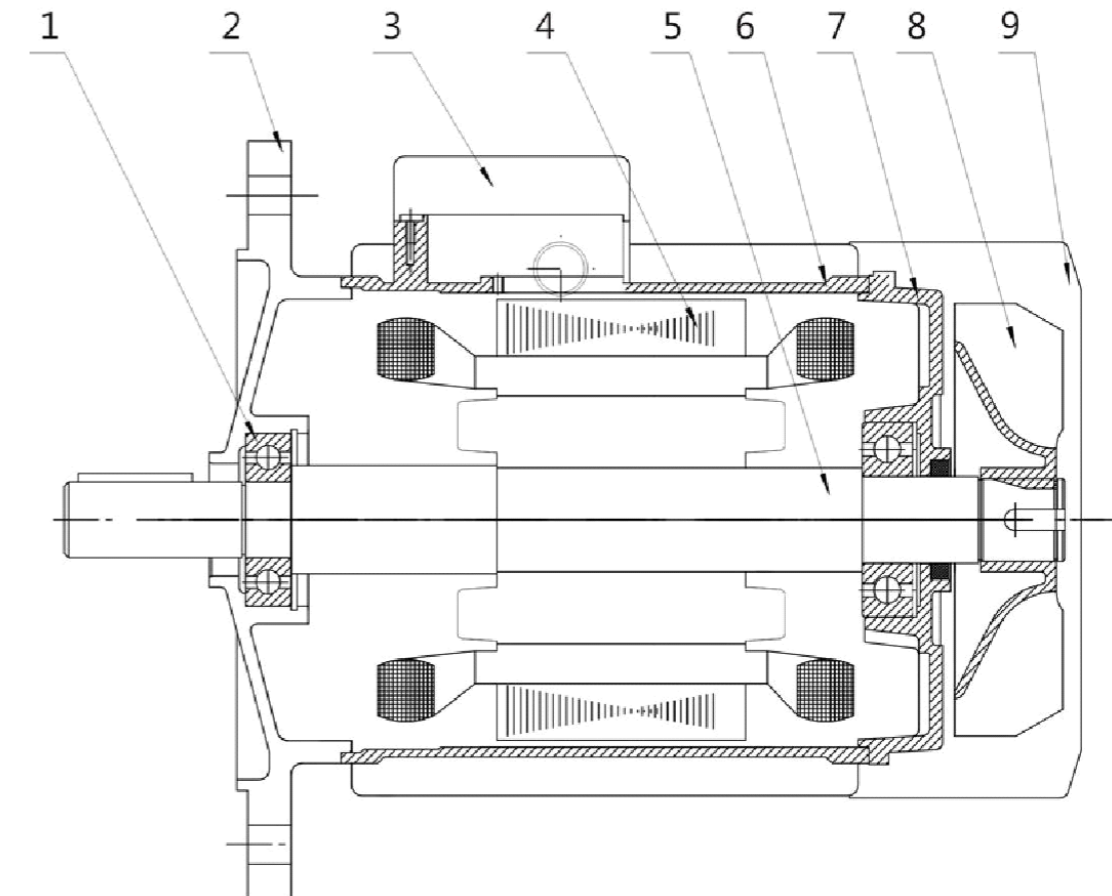

1.轴承 (Bearing)

2.前端盖 (Front Cover)

3.接线盒 (Terminal Box)

4.定子 (Stator)

5.转子 (Rotor)

6.机座(FrameB14,B5)

7.后端盖(Back Cover)

8.风叶(Cooling Fan)

9.风罩(Cooling Fan Cover)

## 型号说明 Model Designation

YE3 80 M2-4-B3-0.75KW

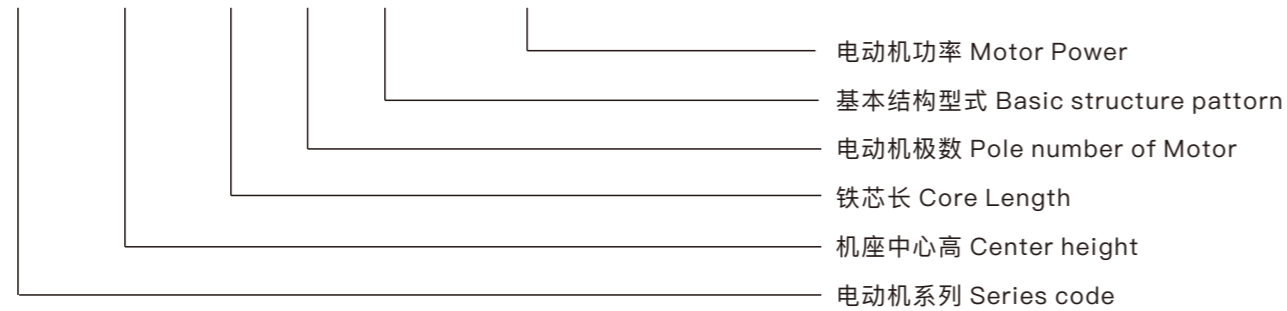

### 产品含义 Definition

YE3: YE3 系列高效率三相异步电动机

YE3 Series high-efficiency 3-phase asynchronous electric motor

例如: YE3 80M2-4-0.75KW 表示中心高为80mm, M 机座2号铁芯, 4极0.75KW 电机。

For example: YE3 80M2-4-0.75KW represent center height of the frame is 80mm, frame is M, core length code 2, 4 pole, 0.75KW.

## 安装形式 Mounting Arrangement

基本结构型式 Basic structure pattern	B3					
安装型式 Intallation pattern	B3	B6	B7	B8	V5	V6
示意图 Diagram						
机座号 Frame No	63-200					

基本结构型式 Basic structure pattern	B5			B35		
安装型式 Intallation pattern	B5	V1	V3	B35	V15	V36
示意图 Diagram						
机座号 Frame No	63-200					

基本结构型式 Basic structure pattern	B34		B14		V18		V19	
安装型式 Intallation pattern								
机座号 Frame No	63-132							

## 技术参数 Technical Parameter

型号 Type	额定功率 Rated Output		额定转速 Rated Speed rpm	效率 Efficiency η% (Ie3)	效率 75%负载 Efficiency at 75% load	效率 50%负载 Efficiency at 50% load	功率因数 Power factor cos φ	额定电流 Rated current A			额定转矩 Rated Torque Nm	堵转转矩 额定转矩 Ts/Tn	最大转矩 额定转矩 Tmax/Tn	堵转电流 额定电流 Is/In	重量 Weight kg
	kW	HP						300V	400V	415V					
同步转速 synchronous speed 3000rpm, 380V 50Hz 2P															
YE3 631-2	0.18	0.25	2730	65.9	65.9	64.6	0.80	0.52	0.49	0.47	0.63	2.2	2.2	5.5	6.1
YE3 632-2	0.25	0.37	2730	69.7	69.7	68.3	0.81	0.67	0.64	0.62	0.87	2.2	2.2	5.5	6.4
YE3 711-2	0.37	0.5	2750	73.8	73.8	72.3	0.81	0.94	0.89	0.86	1.28	2.2	2.2	6.1	6.8
YE3 712-2	0.55	0.75	2750	77.8	77.8	76.2	0.82	1.31	1.24	1.20	1.91	2.3	2.3	6.1	7.9
YE3 801-2	0.75	1	2880	80.7	80.7	79.1	0.82	1.72	1.64	1.58	2.49	2.3	2.3	7.0	8.8
YE3 802-2	1.1	1.5	2880	82.7	82.7	81.0	0.83	2.43	2.31	2.23	3.65	2.2	2.3	7.3	9
YE3 90S-2	1.5	2	2895	84.2	84.2	82.5	0.84	3.22	3.06	2.95	4.95	2.2	2.3	7.6	13.5
YE3 90L-2	2.2	3	2895	85.9	85.9	84.2	0.85	4.58	4.35	4.19	7.26	2.2	2.3	7.6	17
YE3 100L-2	3	4	2895	87.1	87.1	85.4	0.87	6.02	5.71	5.51	9.90	2.2	2.3	7.8	23.2
YE3 112M-2	4	5.5	2905	88.1	88.1	86.3	0.88	7.84	7.45	7.18	13.1	2.2	2.3	8.3	40
YE3 132S1-2	5.5	7.5	2930	89.2	89.2	87.4	0.88	10.6	10.1	9.75	17.9	2.0	2.3	8.3	42
YE3 132S2-2	7.5	10	2930	90.1	90.1	88.3	0.88	14.4	13.7	13.2	24.4	2.0	2.3	7.9	48
YE3 160M1-2	11	15	2945	91.2	91.2	89.4	0.89	20.6	19.6	18.9	35.7	2.0	2.3	8.1	113
YE3 160M2-2	15	20	2945	91.9	91.9	90.1	0.89	27.9	26.5	25.5	48.6	2.0	2.3	8.1	123
YE3 160L-2	18.5	25	2940	92.4	92.4	90.6	0.89	34.2	32.5	31.3	60.1	2.0	2.3	8.2	142
YE3 180M2-2	22	30	2955	92.7	92.7	90.8	0.89	40.5	38.5	37.1	71.1	2.0	2.3	8.2	182
YE3 200L1-2	30	40	2960	93.3	93.3	91.4	0.89	54.9	52.1	50.3	96.8	2.0	2.3	7.6	246
同步转速 synchronous speed 1500rpm, 380V 50Hz 4P															
YE3 631-4	0.12	0.18	1320	64.8	64.8	63.5	0.72	0.39	0.37	0.36	0.87	2.1	2.2	4.4	4.8
YE3 632-4	0.18	0.25	1320	69.9	69.9	68.5	0.73	0.54	0.51	0.49	1.30	2.1	2.2	4.4	5.3
YE3 711-4	0.25	0.37	1340	73.5	73.5	72.0	0.74	0.70	0.66	0.64	1.78	2.1	2.2	5.2	6.8
YE3 712-4	0.37	0.5	1340	77.3	77.3	75.8	0.75	0.97	0.92	0.89	2.64	2.1	2.2	5.2	7.7
YE3 801-4	0.55	0.75	1400	80.8	80.8	79.2	0.75	1.38	1.31	1.26	3.75	2.4	2.3	5.2	9.1
YE3 802-4	0.75	1	1420	82.5	82.5	80.9	0.75	1.84	1.75	1.69	5.04	2.3	2.3	6.6	11.1
YE3 90S-4	1.1	1.5	1445	84.1	84.1	82.4	0.76	2.61	2.48	2.39	7.27	2.3	2.3	6.8	15
YE3 90L-4	1.5	2	1445	85.3	85.3	83.6	0.77	3.47	3.3	3.18	9.91	2.3	2.3	7.0	19
YE3 100L1-4	2.2	3	1450	86.7	86.7	85.0	0.81	4.76	4.52	4.36	14.6	2.3	2.3	7.6	25.4
YE3 100L2-4	3	4	1450	87.7	87.7	85.9	0.82	6.34	6.02	5.8	20.0	2.3	2.3	7.6	30.5
YE3 112M-4	4	5.5	1450	88.6	88.6	86.8	0.82	8.37	7.95	7.66	26.5	2.2	2.3	7.8	37
YE3 132S-4	5.5	7.5	1460	89.6	89.6	87.8	0.83	11.2	10.7	10.3	36.0	2.0	2.3	7.9	48.5
YE3 132M-4	7.5	10	1460	90.4	90.4	88.6	0.84	15.0	14.3	13.7	49.1	2.0	2.3	7.5	60
YE3 160M-4	11	15	1465	91.4	91.4	89.6	0.85	21.5	20.4	19.7	71.7	2.2	2.3	7.7	121
YE3 160L-4	15	20	1465	92.1	92.1	90.3	0.86	28.8	27.3	26.3	97.8	2.2	2.3	7.8	142
YE3 180M-4	18.5	25	1470	92.6	92.6	90.7	0.86	35.3	33.5	32.3	120.2	2.0	2.3	7.8	181
YE3 180L-4	22	30	1470	93	93	91.1	0.86	41.8	39.7	38.3	142.9	2.0	2.3	7.8	209
YE3 200L-4	30	40	1475	93.6	93.6	91.7	0.86	56.6	53.8	51.8	194.2	2.0	2.3	7.3	284
同步转速 synchronous speed 1000rpm, 380V 50Hz 6P															
YE3 632-6	0.12	0.18	855	57.7	57.7	56.5	0.6	0.53	0.50	0.48	1.34	1.8	1.9	3.5	6.2
YE3 711-6	0.18	0.25	855	63.9	63.9	62.6	0.66	0.65	0.62	0.59	2.01	1.9	2	4.0	9.3
YE3 712-6	0.25	0.37	855	68.6	68.6	67.2	0.68	0.81	0.77	0.75	2.79	1.9	2	4.0	9.7
YE3 801-6	0.37	0.5	890	73.5	73.5	72	0.7	1.09	1.04	1	3.97	1.9	2	4.7	12.2
YE3 802-6	0.55	0.75	890	77.2	77.2	75.7	0.72	1.50	1.43	1.38	5.90	1.9	2.1	4.7	13.2
YE3 90S-6	0.75	1	935	78.9	78.9	77.3	0.71	2.03	1.93	1.86	7.66	2.0	2.1	6.0	14
YE3 90L-6	1.1	1.5	945	81.0	81.0	79.4	0.73	2.83	2.69	2.59	11.1	2.0	2.1	6.0	18
YE3 100L-6	1.5	2	949	82.5	82.5	80.9	0.73	3.78	3.59	3.47	15.1	2.0	2.1	6.5	29.5
YE3 112M-6	2.2	3	955	84.3	84.3	82.6	0.74	5.36	5.09	4.91	22.0	2.0	2.1	6.6	32
YE3 132S-6	3	4	968	85.6	85.6	83.9	0.74	7.20	6.84	6.59	29.6	2.0	2.1	6.8	43
YE3 132M1-6	4	5.5	968	86.8	86.8	85.1	0.74	9.46	8.99	8.66	39.5	2.0	2.1	6.8	49
YE3 132M2-6	5.5	7.5	968	88	88	86.2	0.75	12.7	12.0	11.6	54.3	2.0	2.1	7.0	59
YE3 160M-6	7.5	10	970	89.1	89.1	87.3	0.79	16.2	15.4	14.8	73.8	2.0	2.1	7.0	112
YE3 160L-6	11	15	970	90.3	90.3	88.5	0.8	23.1	22.0	21.2	108.3	2.0	2.1	7.2	134
YE3 180L-6	15	20	978	91.2	91.2	89.4	0.81	30.9	29.3	28.2	146.5	2.0	2.1	7.3	197
YE3 200L1-6	18.5	25	980	91.7	91.7	89.9	0.81	37.8	35.9	34.7	180.3	2.0	2.1	7.3	234
YE3 200L2-6	22	30	980	92.2	92.2	90.4	0.81	44.8	42.5	41.0	214.4	2.0	2.1	7.4	251

注:表格内白底部分电机外壳材质为铝壳, 灰底部分电机外壳材质为铁壳

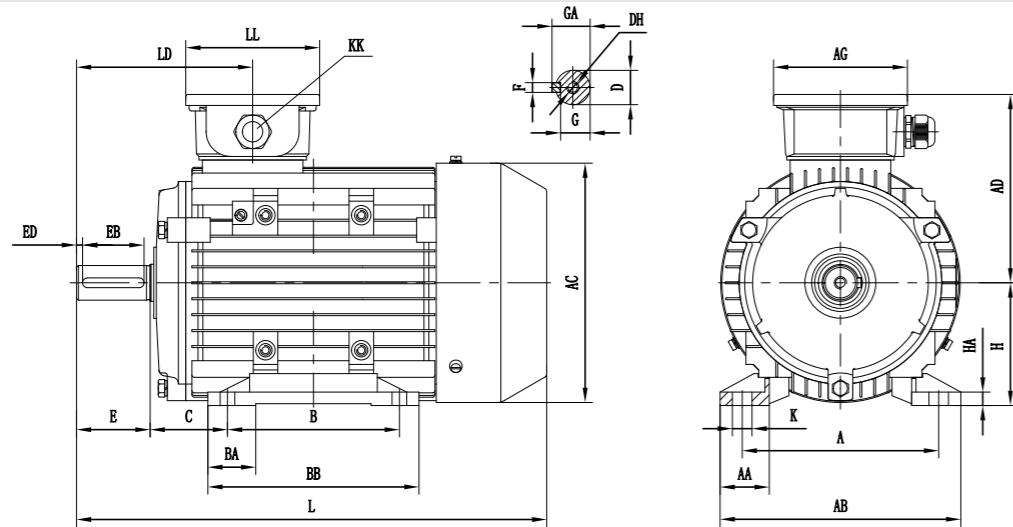
**安装位置和尺寸图 Mounting position & Dimension**
**YE3 63-200-B3**

型号 TYPE	极数 POLE	A	AA	AB	AC	AD	AG	B	BA	BB	C	D	DH
63	2,4,6	100	24	123	120	102	101	80	22.5	100	40	11	M4X12
71	2,4,6	112	26	138	136	109	101	90	25.5	110	45	14	M5X12
80	2,4,6,8	125	35	157	158	129	101	100	27.5	125	50	19	M6X16
90S	2,4,6,8	140	37	173	175	140	109	100	31	125	56	24	M8X19
90L	2,4,6,8	140	37	173	175	140	109	125	31.5	150	56	24	M8X19
100L	2,4,6,8	160	40	196	198	156	109	140	31.5	172	63	28	M10X22
112M	2,4,6,8	190	40	227	230	178	117.5	140	39	180	70	28	M10X22
132S	2,4,6,8	216	51	262	258	188	117.5	140	43	186	89	38	M12X28
132M	4,6,8	216	51	262	258	188	117.5	178	46	224	89	38	M12X28
160M	2,4,6,8	254	65	314	314	251	162	210	-	260	108	42	M16X36
160L	2,4,6,8	254	65	314	314	251	162	254	-	304	108	42	M16X36
180M	2,4,8	279	70	349	355	267	162	241	-	311	121	48	M16X36
180L	4,6,8	279	70	349	355	267	162	279	-	349	121	48	M16X36
200L	2,4,6,8	318	70	388	397	299	210	305	-	369	133	55	M20X42

型号 TYPE	E	EB	ED	F	G	GA	H	HA	K	KK	L	LD	LL
63	23	16	3.5	4	8.5	12.5	63	7	7x9.5	1-M20x1.5	217	95.5	101
71	30	25	2.5	5	11	16	71	8	7x11	1-M20x1.5	245	110.5	101
80	40	30	5	6	15.5	21.5	80	8	10x14	1-M20x1.5	290	115	101
90S	50	40	5	8	20	27	90	10	10x14	1-M20x1.5	325	145	109
90L	50	40	5	8	20	27	90	10	10x14	1-M25x1.5	350	145	109
100L	60	50	5	8	24	31	100	11	12x16	1-M32x1.5	398	148.5	109
112M	60	50	5	8	24	31	112	12	12x16	2-M32x1.5	394	154	117.5
132S	80	65	7.5	10	33	41	132	15	12x16	2-M32x1.5	475	180	117.5
132M	80	65	7.5	10	33	41	132	15	12x16	2-M32x1.5	513	180	117.5
160M	110	90	10	12	37	45	160	20	4xΦ14.5	2-M40x1.5	608	256	152
160L	110	90	10	12	37	45	160	20	4xΦ14.5	2-M40x1.5	652	256	152
180M	110	90	10	14	42.5	51.5	180	22	4xΦ14.5	2-M40x1.5	688	271	152
180L	110	90	10	14	42.5	51.5	180	22	4xΦ14.5	2-M40x1.5	726	271	152
200L	110	100	5	16	49	59	200	25	4xΦ18.5	2-M50x1.5	779	296	190

注:表格内白底部分电机外壳材质为铝壳, 灰底部分电机外壳材质为铁壳

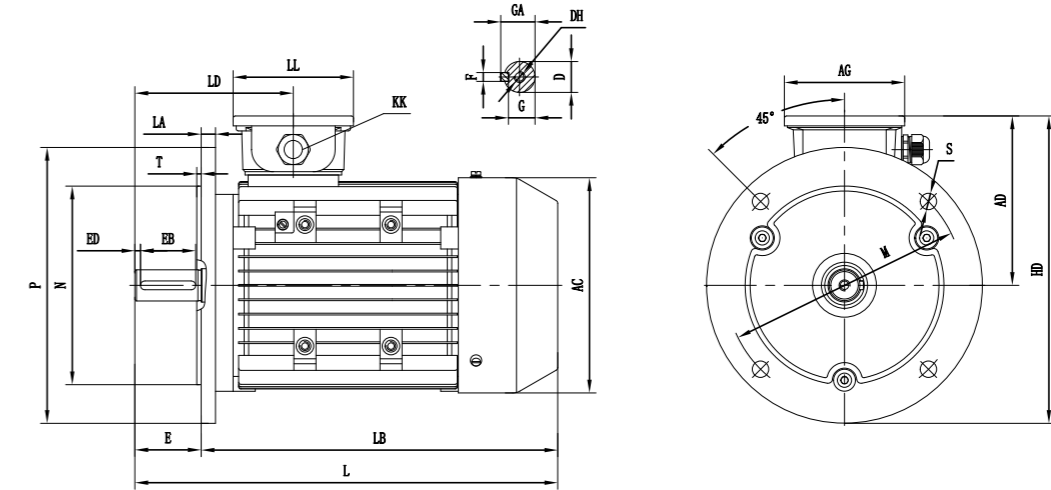
**YE3 63-200-B5**

型号 TYPE	极数 POLE	AC	AD	AG	D	DH	E	EB	ED	F	G	GA
63	2,4,6	120	102	101	11	M4x12	23	16	3.5	4	8.5	12.5
71	2,4,6	136	109	101	14	M5x12	30	25	2.2	5	11	16
80	2,4,6,8	158	129	101	19	M6x16	40	30	5	6	15.5	21.5
90S	2,4,6,8	175	140	109	24	M8x19	50	40	5	8	20	27
90L	2,4,6,8	175	140	109	24	M8x19	50	40	5	8	20	27
100L	2,4,6,8	198	156	109	28	M10x22	60	50	5	8	24	31
112M	2,4,6,8	230	176	117.5	28	M10x22	60	50	5	8	24	31
132S	2,4,6,8	258	188	117.5	38	M12x28	80	65	7.5	10	33	41
132M	4,6,8	258	188	117.5	38	M12x28	80	65	7.5	10	33	41
160M	2,4,6,8	314	251	162	42	M16x36	110	90	10	12	37	45
160L	2,4,6,8	314	251	162	42	M16x36	110	90	10	12	37	45
180M	2,4,8	355	267	162	48	M16x36	110	90	10	14	42.5	51.5
180L	4,6,8	355	267	162	48	M16x36	110	90	10	14	42.5	51.5
200L	2,4,6,8	397	299	210	55	M20x42	110	100	5	16	49	59

型号 TYPE	HD	KK	L	LA	LB	LD	LL	M	N	P	S	T
63	172	1-M20x1.5	217	10	194	95.5	101	115	95	140	10	3
71	189	1-M20x1.5	245	10	215	110.5	101	130	110	160	10	3.5
80	229	1-M25x1.5	290	12	250	115	101	165	130	200	12	3.5
90S	240	1-M25x1.5	325	12	275	145	109	165	130	200	12	3.5
90L	240	1-M25x1.5	350	12	300	145	109	165	130	200	12	3.5
100L	281	1-M32x1.5	398	13	338	148.5	109	215	180	250	14.5	4
112M	301	2-M32x1.5	394	14	334	154	117.5	215	180	250	14.5	4
132S	338	2-M32x1.5	475	14	395	180	117.5	265	230	300	14.5	4
132M	338	2-M32x1.5	513	14	433	180	117.5	265	230	300	14.5	4
160M	426	2-M40x1.5	608	15	498	256	152	300	250	350	18.5	5
160L	426	2-M40x1.5	652	15	542	256	152	300	250	350	18.5	5
180M	444.5	2-M40x1.5	688	15	578	271	152	300	250	350	18.5	5
180L	444.5	2-M40x1.5	726	15	616	271	152	300	250	350	18.5	5
200L	499	2-M50x1.5	779	17	669	296	190	350	300	400	18.5	5

注:表格内白底部分电机外壳材质为铝壳, 灰底部分电机外壳材质为铁壳

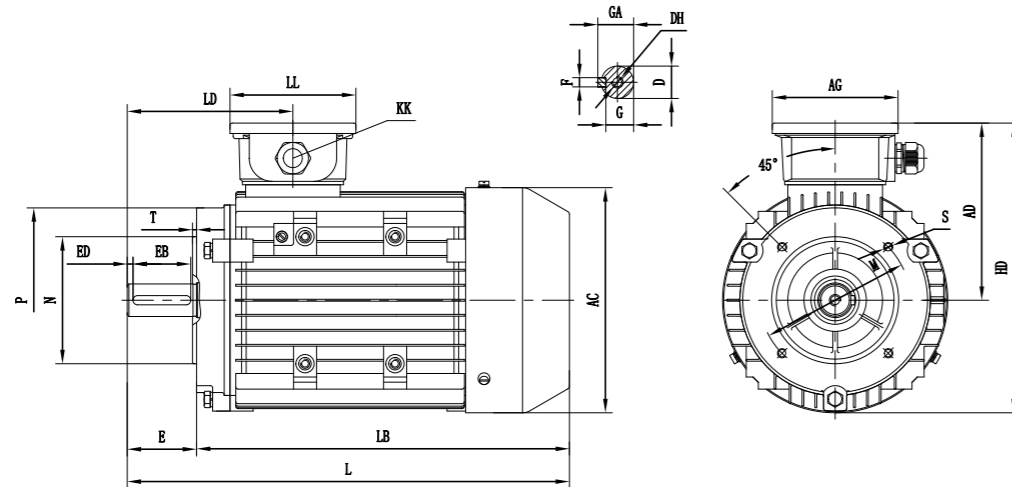
**安装位置和尺寸图 Mounting position & Dimension**
**YE3 63-132-B14**

型号 TYPE	AC	AD	AG	D	DH	E	EB	ED	F	G	GA
63	120	102	101	11	M4X12	23	16	3.5	4	8.5	12.5
71	136	109	101	14	M5X12	30	25	2.5	5	11	16
80	158	129	101	19	M6X16	40	30	5	6	15.5	21.5
90S	175	140	109	24	M8X19	50	40	5	8	20	27
90L	175	140	109	24	M8X19	50	40	5	8	20	27
100L	198	156	109	28	M10X22	60	50	5	8	24	31
112M	230	176	117.5	28	M10X22	60	50	5	8	24	31
132S	258	188	117.5	38	M12X28	80	65	7.5	10	33	41
132M	258	188	117.5	38	M12X28	80	65	7.5	10	33	41

型号 TYPE	HD	METRIC	L	LB	LD	LL	M	N	P	S	T
63	162	1-M20x1.5	217	194	95.5	101	75	60	90	M5	2.5
71	177	1-M20x1.5	245	215	110.5	101	85	70	105	M6	2.5
80	208	1-M25x1.5	290	250	115	101	100	80	120	M6	3
90S	227.5	1-M25x1.5	325	275	145	109	115	95	140	M8	3
90L	227.5	1-M25x1.5	350	300	145	109	115	95	140	M8	3
100L	255	1-M32x1.5	398	338	148.5	109	130	110	160	M8	3.5
112M	291	2-M32x1.5	394	334	154	117.5	130	110	160	M8	3.5
132S	317	2-M32x1.5	475	395	180	117.5	165	130	200	M10	3.5
132M	317	2-M32x1.5	513	433	180	117.5	165	130	200	M10	3.5

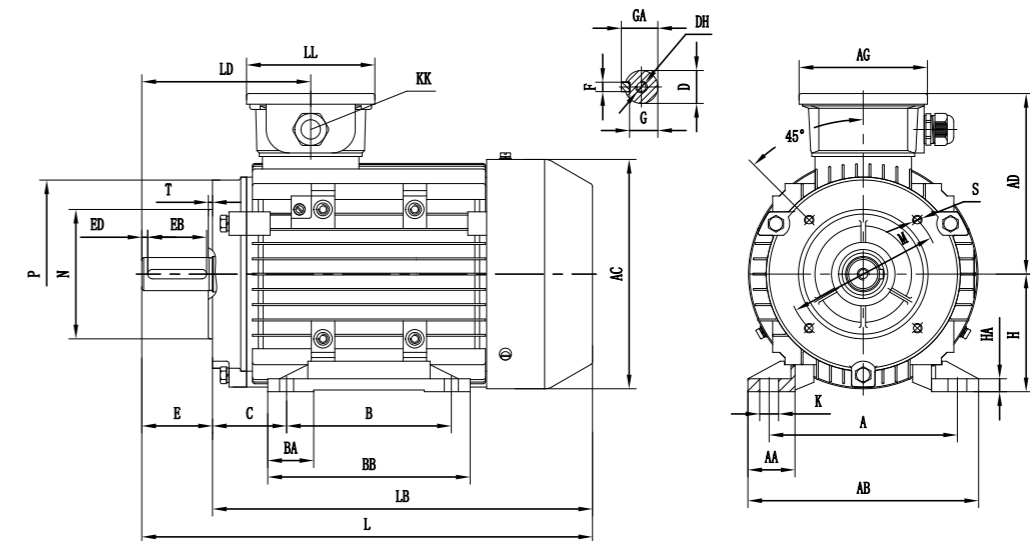
**TE3 63-132-B34**

型号 TYPE	A	AA	AB	AC	AD	AG	B	BA	BB	C	D	DH	E	EB	ED
63	100	24	123	120	102	101	80	25.5	100	40	11	M4X12	23	16	3.5
71	112	26	138	136	109	101	90	27.5	110	45	14	M5X12	30	25	2.5
80	125	35	157	158	129	101	100	31	125	50	19	M6X16	40	30	5
90S	140	37	173	175	140	109	100	31.5	125	56	24	M8X19	50	40	5
90L	140	37	173	175	140	109	125	31.5	150	56	24	M8X19	50	40	5
100L	160	40	196	198	156	109	140	39	172	63	28	M10X22	60	50	5
112M	190	40	227	230	176	117.5	140	43	180	70	28	M10X22	60	50	5
132S	216	51	262	258	188	117.5	140	46	186	89	38	M12X28	80	65	7.5
132M	216	51	262	258	188	117.5	178	46	224	89	38	M12X28	80	65	7.5

型号 TYPE	F	G	GA	H	HA	K	METRIC	L	LB	LD	LL	M	N	P	S	T
63	4	8.5	12.5	63	7	7X9.5	1-M20X1.5	217	194	95.5	101	75	60	90	M5	2.5
71	5	11	16	71	8	7X11	1-M20X1.5	245	215	110.5	101	85	70	105	M6	3
80	6	15.5	21.5	80	8	10X14	1-M25X1.5	290	250	115	101	100	80	120	M6	3
90S	8	20	27	90	10	10X14	1-M25X1.5	325	275	145	109	115	95	140	M8	3.5
90L	8	20	27	90	10	10X14	1-M25X1.5	350	300	145	109	115	95	140	M8	3.5
100L	8	24	31	100	11	12X16	1-M32X1.5	398	338	148.5	109	130	110	160	M8	3.5
112M	8	24	31	112	12	12X16	2-M32X1.5	394	334	154	117.5	130	110	160	M8	3.5
132S	10	33	41	132	15	12X16	2-M32X1.5	475	395	180	117.5	165	130	200	M8	4
132M	10	33	41	132	15	12X16	2-M32X1.5	513	433	180	117.5	165	130	200	M8	4

**安装位置和尺寸图 Mounting position & Dimension**

**YE3 63-200-B35**

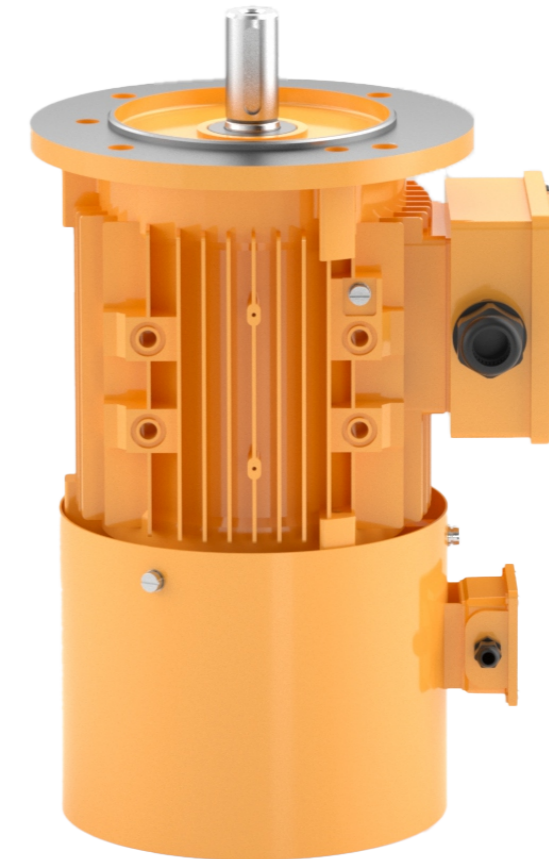
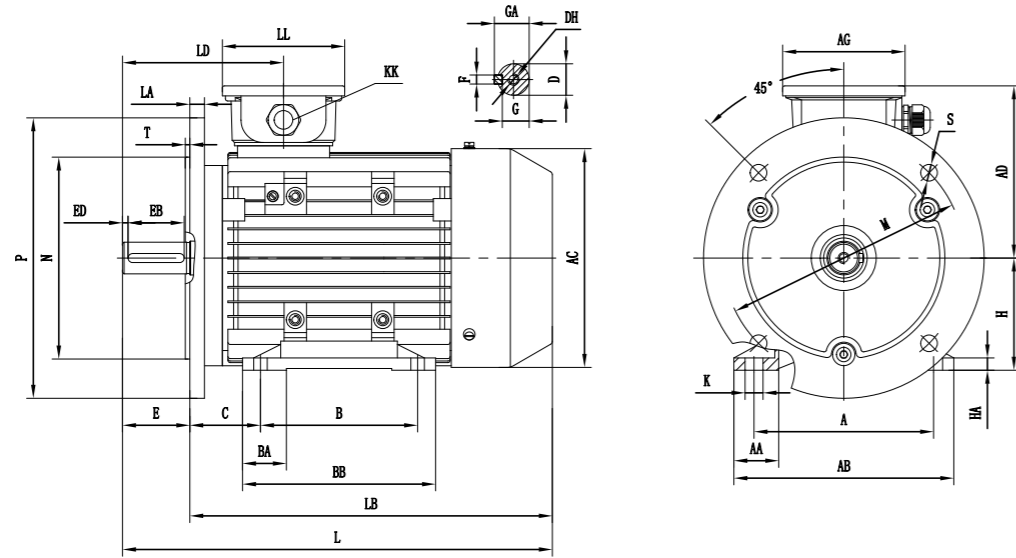

型号 TYPE	极数 POLE	A	AA	AB	AC	AD	AG	B	BA	BB	C	D	DH	E	EB	ED
63	2,4,6	100	24	123	120	102	101	80	25.5	100	40	11	M4×12	23	16	3.5
71	2,4,6	112	26	138	136	109	101	90	27.5	110	45	14	M5×12	30	25	2.5
80	2,4,6,8	125	35	157	158	129	101	100	31	125	50	19	M6×16	40	30	5
90S	2,4,6,8	140	37	173	175	140	109	100	31.5	125	56	24	M8×19	50	40	5
90L	2,4,6,8	140	37	173	175	140	109	125	31.5	150	56	24	M8×19	50	40	5
100L	2,4,6,8	160	40	196	198	156	109	140	39	172	63	28	M10×22	60	50	5
112M	2,4,6,8	190	40	227	230	176	117.5	140	43	180	70	28	M10×22	60	50	5
132S	2,4,6,8	216	51	262	258	188	117.5	140	46	186	89	38	M12×28	80	65	7.5
132M	4,6,8	216	51	262	258	188	117.5	178	46	224	89	38	M12×28	80	65	7.5
160M	2,4,6,8	254	65	314	314	251	162	210	-	260	108	42	M16×36	110	90	10
160L	2,4,6,8	254	65	314	314	251	162	254	-	304	108	42	M16×36	110	90	10
180M	2,4,8	279	70	349	355	267	162	241	-	311	121	48	M16×36	110	90	10
180L	4,6,8	279	70	349	355	267	162	279	-	349	121	48	M16×36	110	90	10
200L	2,4,6,8	318	70	388	397	299	210	305	-	369	133	55	M20×42	110	100	5

型号 TYPE	F	G	GA	H	HA	K	KK	L	LA	LB	LD	LL	M	N	P	S	T
63	4	8.5	12.5	63	7	7×9.5	1-M20×1.5	217	10	194	95.5	101	115	95	140	10	3
71	5	11	16	71	8	7×11	1-M20×1.5	245	10	215	110.5	101	130	110	160	10	3.5
80	6	15.5	21.5	80	8	10×14	1-M25×1.5	290	12	250	115	101	165	130	200	12	3.5
90S	8	20	27	90	10	10×14	1-M25×1.5	325	12	275	145	109	165	130	200	12	3.5
90L	8	20	27	90	10	10×14	1-M25×1.5	350	12	300	145	109	165	130	200	12	3.5
100L	8	24	31	100	11	12×16	1-M32×1.5	398	13	338	148.5	109	215	180	250	14.5	4
112M	8	24	31	112	12	12×16	2-M32×1.5	394	14	334	154	117.5	215	180	250	14.5	4
132S	10	33	41	132	15	12×16	2-M32×1.5	475	14	395	180	117.5	265	230	300	14.5	4
132M	10	33	41	132	15	12×16	2-M32×1.5	513	14	433	180	117.5	265	230	300	14.5	4
160M	12	37	45	160	20	4-Φ14.5	2-M40×1.5	589	15	498	256	152	300	250	350	18.5	5
160L	12	37	45	160	20	4-Φ14.5	2-M40×1.5	633	15	542	256	152	300	250	350	18.5	5
180M	14	42.5	51.5	180	22	4-Φ14.5	2-M40×1.5	661	15	578	271	152	300	250	350	18.5	5
180L	14	42.5	51.5	180	22	4-Φ14.5	2-M40×1.5	726	15	616	271	152	300	250	350	18.5	5
200L	16	49	59	200	25	4-Φ18.5	2-M50×1.5	757	17	669	296	190	350	300	400	18.5	5

注:表格内白底部分电机外壳材质为铝壳, 灰底部分电机外壳材质为铁壳

**YVF系列变频调速电机**  
YVF SERIES FREQUENCY VARIABLE SPEED MOTOR

## 概述 Generalization

YVF系列变频调速电动机吸收了德国、日本等先进国家产品之优点，应用计算机辅助设计技术进行设计。可与国内外同类型变频装置配套、互换性、通用性强。电机采用鼠笼型结构，外形结构新颖美观，噪声低、振动小，运行可靠，维护方便。电机具有较宽的调速范围，且单独装有轴流风机，保证电机在不同转速下均有较好的冷却效果，保证电机可低速长期运行。电机绝缘采用国际上广为使用的F级绝缘结构，电机与各类变频器具有良好的参数匹配，配合矢量控制具有快速动态响应，低速无转矩脉动，无共振现象，提高了电机的可靠性。电机的功率、底脚安装尺寸和中心高等对应指标与XGY系列异步电机完全一致。本系列电机可广泛应用于陶瓷、纺织、轻工、化工、冶金、机床等需要调速转动装置的行业中，是一种理想的调速动力源。

YVF series variable frequency adjustable speed motors are designed with computer-aided design technology, taking advantage of the advantages of German, Japanese and other advanced countries Project. It can be matched with the same type of frequency conversion device at home and abroad, and has strong interchangeability and versatility. The motor adopts squirrel cage structure, with novel and beautiful appearance, low noise, small vibration, reliable operation, easy maintenance. Motor has a wide speed range, and equipped with a separate axial flow fan to ensure that the motor in The cooling effect was good at different rotating speeds, which ensured that the motor could run for a long time at low speed. The insulation of motor adopts Class F insulation junction which is widely used in the world Structure, motor and all kinds of inverter have a good parameter matching, with vector control has a fast dynamic response, low-speed no torque ripple, no common Vibration phenomenon, improve the reliability of the motor. Motor Power, foot installation size and center height corresponding indicators with XGY series asynchronous motor all the same. This series of motors can be widely used in ceramic, textile, light industry, chemical industry, metallurgy, machine tools and other industries that need speed control rotating device. It is an ideal power source for speed regulation.

## 型号说明 Model Designation

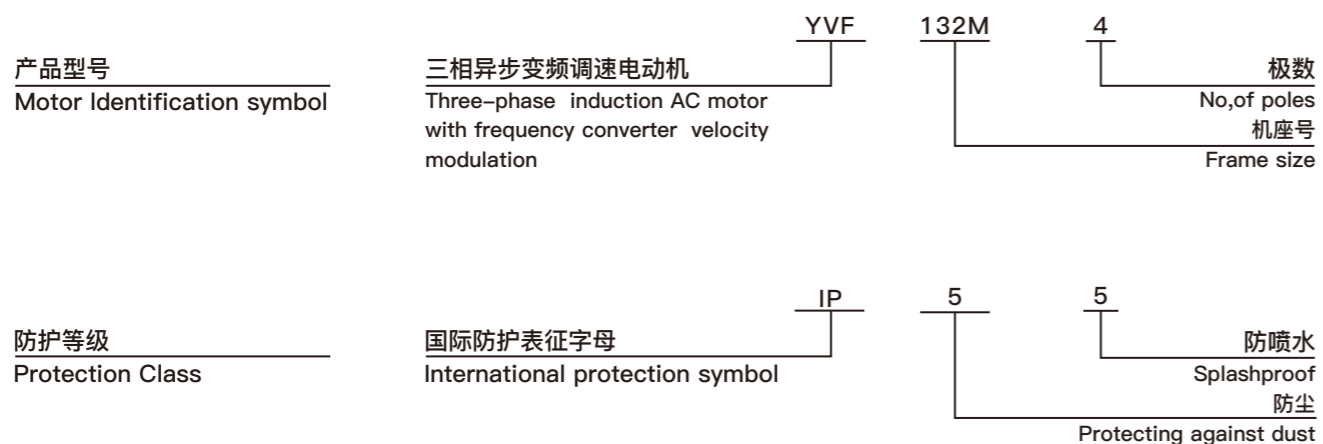

## 功率与机座号的对应关系表 OUTPUT AND FRAME SIZE

功率 Rated Output	机座号 Frame Size			
	2P	4P	6P	8P
0.25	-	711	-	-
0.37	711	712	801	-
0.55	712	801	802	-
0.75	801	802	90S	100L1
1.1	802	90S	90L	100L2
1.5	90S	90L	100L	112M
2.2	90L	100L1	112M	132S
3	100L	100L2	132S	132M
4	112M	112M	312M1	160M1
5.5	132S	132S	312M2	160M2
7.5	132S2	132S2	160M	160L
11	160M1	160M1	160L	180L
15	160M2	160M2	180L	200L
18.5	160L	160L	200L1	225S
22	180M	180L	200L2	225M
30	200L1	200L	225M	250M

## 额定转矩、标称功率与调频范围的对应关系表 RATED TORQUE, RATING OUTPUT AND FREQUENCY RANGE

功率 Output KW	3000 r/min	恒转矩调频范围 Constant torque frequency-varied range Hz	恒功率调频范围 Constant power frequency-varied range Hz	1500 r/min	1000 r/min	750 r/min
	额定转矩 Rated torque Nm	额定转矩 Rated torque				
0.25		5-50	50-120	1.73	2.65	3.46
0.37	1.26			2.54	3.93	5.12
0.55	1.88			3.78	5.84	7.61
0.75	2.54			5.15	7.87	10.23
1.1	3.72			7.50	11.54	15.00
1.5	5.04			10.23	15.24	20.46
2.2	7.40			14.80	22.35	29.59
3	9.95	20.18	29.84	40.35		
4	13.22	26.53	39.79	53.06		
5.5	18.11	36.48	54.71	72.59		
7.5	24.00	49.74	73.84	99.50		
11	35.85	5-50	50-100	71.59	108.30	143.90
15	48.89			98.12	147.68	196.23
18.5	60.30			142.93	216.60	287.81
22	71.46			160.96	292.35	382.47
30	79.12					

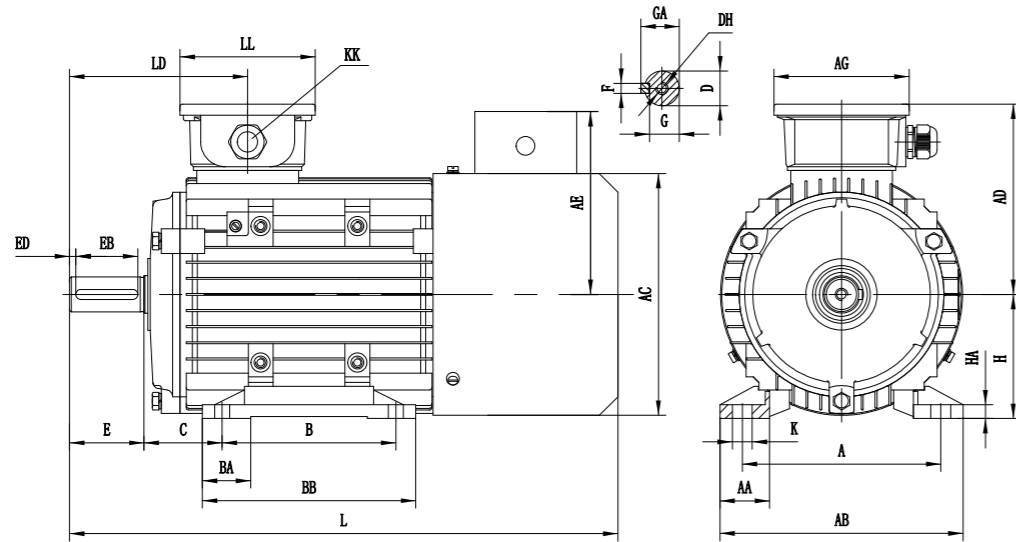
**安装位置和尺寸图 Mounting position & Dimension**
**YVF63-160-B3**

型号 TYPE	极数 POLE	A	AA	AB	AC	AD	AE	AG	B	BA	BB	C	D	DH
63	2,4,6	100	24	123	120	102	110	101	80	22.5	100	40	11	M4X12
71	2,4,6	112	26	138	136	109	118	101	90	25.5	110	45	14	M5X12
80	2,4,6,8	125	35	157	158	129	129	101	100	27.5	125	50	19	M6X16
90S	2,4,6,8	140	37	173	175	140	137.5	109	100	31	125	56	24	M8X19
90L	2,4,6,8	140	37	173	175	140	137.5	109	125	31.5	150	56	24	M8X19
100L	2,4,6,8	160	40	196	198	156	149	109	140	31.5	172	63	28	M10X22
112M	2,4,6,8	190	40	227	230	178	165	117.5	140	39	180	70	28	M10X22
132S	2,4,6,8	216	51	262	258	188	179	117.5	140	43	186	89	38	M12X28
132M	4,6,8	216	51	262	258	188	179	117.5	178	46	224	89	38	M12X28
160M	2,4,6,8	254	65	314	314	251	207	162	210	-	260	108	42	M16X36
160L	2,4,6,8	254	65	314	314	251	207	162	254	-	304	108	42	M16X36

型号 TYPE	E	EB	ED	F	G	GA	H	HA	K	KK	L	LD	LL
63	23	16	3.5	4	8.5	12.5	63	7	7×9.5	1-M20×1.5	279.5	95.5	101
71	30	25	2.5	5	11	16	71	8	7×11	1-M20×1.5	300.5	110.5	101
80	40	30	5	6	15.5	21.5	80	8	10×14	1-M20×1.5	345.5	115	101
90S	50	40	5	8	20	27	90	10	10×14	1-M20×1.5	388	145	109
90L	50	40	5	8	20	27	90	10	10×14	1-M25×1.5	413	145	109
100L	60	50	5	8	24	31	100	11	12×16	1-M32×1.5	461	148.5	109
112M	60	50	5	8	24	31	112	12	12×16	2-M32×1.5	484	154	117.5
132S	80	65	7.5	10	33	41	132	15	12×16	2-M32×1.5	565	180	117.5
132M	80	65	7.5	10	33	41	132	15	12×16	2-M32×1.5	608.5	180	117.5
160M	110	90	10	12	37	45	160	20	4×Φ14.5	2-M40×1.5	703.5	256	152
160L	110	90	10	12	37	45	160	20	4×Φ14.5	2-M40×1.5	747.5	256	152

注:表格内白底部分电机外壳材质为铝壳, 灰底部分电机外壳材质为铁壳

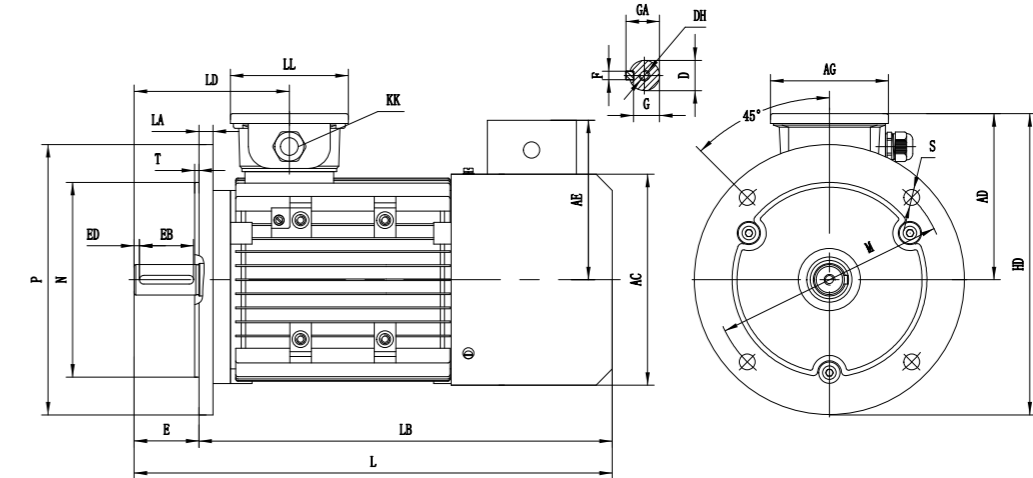
**YVF63-160-B5**

型号 TYPE	极数 POLE	AC	AD	AE	AG	D	DH	E	EB	ED	F	G
63	2,4,6	120	102	110	101	11	M4×12	23	16	3.5	4	8.5
71	2,4,6	136	109	118	101	14	M5×12	30	25	2.2	5	11
80	2,4,6,8	158	129	129	101	19	M6×16	40	30	5	6	15.5
90S	2,4,6,8	175	140	137.5	109	24	M8×19	50	40	5	8	20
90L	2,4,6,8	175	140	137.5	109	24	M8×19	50	40	5	8	20
100L	2,4,6,8	198	156	149	109	28	M10×22	60	50	5	8	24
112M	2,4,6,8	230	176	165	117.5	28	M10×22	60	50	5	8	24
132S	2,4,6,8	258	188	179	117.5	38	M12×28	80	65	7.5	10	33
132M	4,6,8	258	188	179	117.5	38	M12×28	80	65	7.5	10	33
160M	2,4,6,8	314	251	207	162	42	M16×36	110	90	10	12	37
160L	2,4,6,8	314	251	207	162	42	M16×36	110	90	10	12	37

型号 TYPE	GA	HD	KK	L	LA	LB	LD	LL	M	N	P	S	T
63	12.5	172	1-M20×1.5	279.5	10	194	95.5	101	115	95	140	10	3
71	16	189	1-M20×1.5	300.5	10	215	110.5	101	130	110	160	10	3.5
80	21.5	229	1-M25×1.5	345.5	12	250	115	101	165	130	200	12	3.5
90S	27	240	1-M25×1.5	388	12	275	145	109	165	130	200	12	3.5
90L	27	240	1-M25×1.5	413	12	300	145	109	165	130	200	12	3.5
100L	31	281	1-M32×1.5	461	13	338	148.5	109	215	180	250	14.5	4
112M	31	301	2-M32×1.5	484	14	334	154	117.5	215	180	250	14.5	4
132S	41	338	2-M32×1.5	565	14	395	180	117.5	265	230	300	14.5	4
132M	41	338	2-M32×1.5	608.5	14	433	180	117.5	265	230	300	14.5	4
160M	45	426	2-M40×1.5	703.5	15	498	256	152	300	250	350	18.5	5
160L	45	426	2-M40×1.5	747.5	15	542	256	152	300	250	350	18.5	5

注:表格内白底部分电机外壳材质为铝壳, 灰底部分电机外壳材质为铁壳

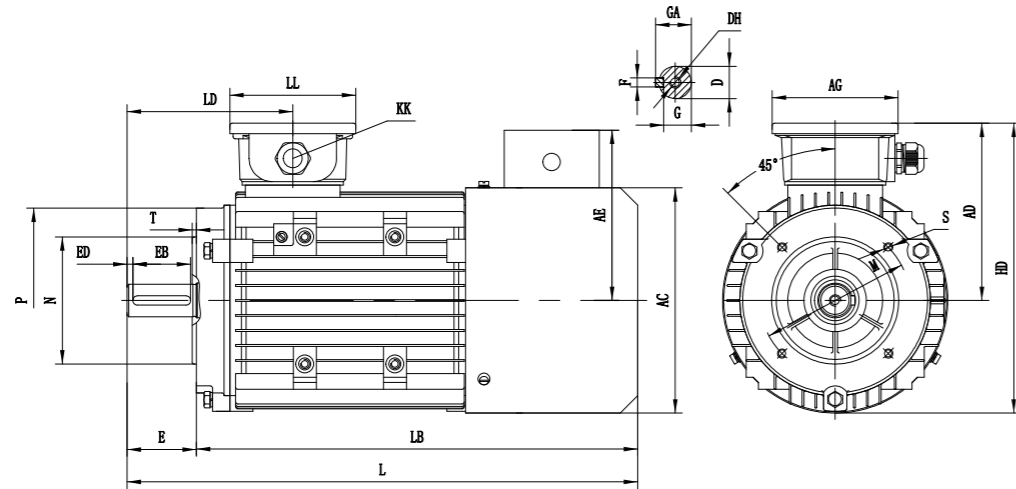
**安装位置和尺寸图 Mounting position & Dimension**
**YVF63-160-B14**

型号 TYPE	AC	AD	AE	AG	D	DH	E	EB	ED	F	G
63	120	102	110	101	11	M4X12	23	16	3.5	4	8.5
71	136	109	118	101	14	M5X12	30	25	2.5	5	11
80	158	129	129	101	19	M6X16	40	30	5	6	15.5
90S	175	140	137.5	109	24	M8X19	50	40	5	8	20
90L	175	140	137.5	109	24	M8X19	50	40	5	8	20
100L	198	156	149	109	28	M10X22	60	50	5	8	24
112M	230	176	165	117.5	28	M10X22	60	50	5	8	24
132S	258	188	179	117.5	38	M12X28	80	65	7.5	10	33
132M	258	188	179	117.5	38	M12X28	80	65	7.5	10	33

型号 TYPE	GA	HD	METRIC	L	LB	LD	LL	M	N	P	S	T
63	12.5	162	1-M20x1.5	279.5	194	95.5	101	75	60	90	M5	2.5
71	16	177	1-M20x1.5	300.5	215	110.5	101	85	70	105	M6	2.5
80	21.5	208	1-M25x1.5	345.5	250	115	101	100	80	120	M6	3
90S	27	227.5	1-M25x1.5	388	275	145	109	115	95	140	M8	3
90L	27	227.5	1-M25x1.5	413	300	145	109	115	95	140	M8	3
100L	31	255	1-M32x1.5	461	338	148.5	109	130	110	160	M8	3.5
112M	31	291	2-M32x1.5	484	334	154	117.5	130	110	160	M8	3.5
132S	41	317	2-M32x1.5	565	395	180	117.5	165	130	200	M10	3.5
132M	41	317	2-M32x1.5	608.5	433	180	117.5	165	130	200	M10	3.5

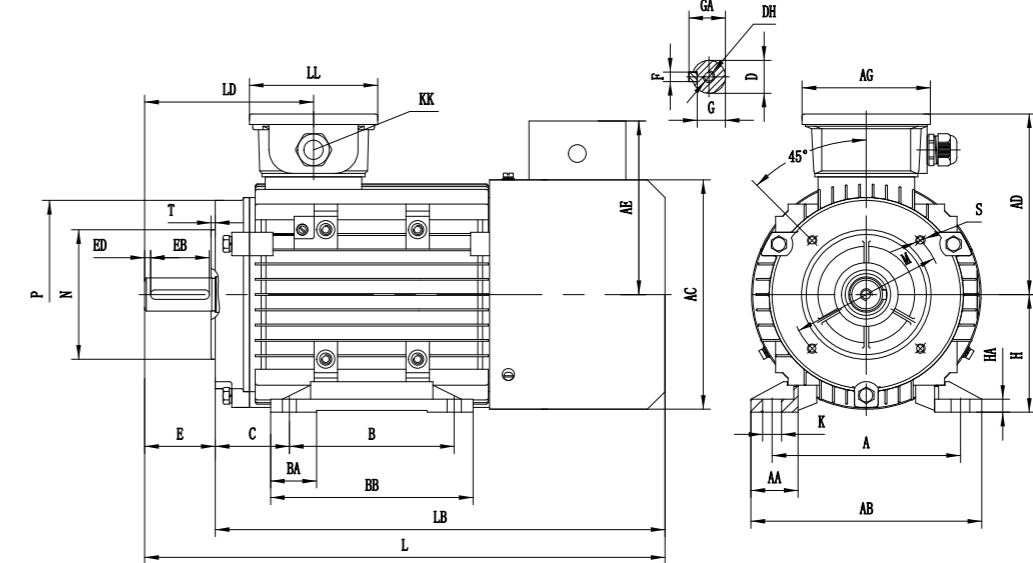
**YVF63-160-B34**

型号 TYPE	A	AA	AB	AC	AD	AE	AG	B	BA	BB	C	D	DH	E	EB	ED
63	100	24	123	120	102	110	101	80	25.5	100	40	11	M4X12	23	16	3.5
71	112	26	138	136	109	118	101	90	27.5	110	45	14	M5X12	30	25	2.5
80	125	35	157	158	129	129	101	100	31	125	50	19	M6X16	40	30	5
90S	140	37	173	175	140	137.5	109	100	31.5	125	56	24	M8X19	50	40	5
90L	140	37	173	175	140	137.5	109	125	31.5	150	56	24	M8X19	50	40	5
100L	160	40	196	198	156	149	109	140	39	172	63	28	M10X22	60	50	5
112M	190	40	227	230	176	165	117.5	140	43	180	70	28	M10X22	60	50	5
132S	216	51	262	258	188	179	117.5	140	46	186	89	38	M12X28	80	65	7.5
132M	216	51	262	258	188	179	117.5	178	46	224	89	38	M12X28	80	65	7.5

型号 TYPE	F	G	GA	H	HA	K	METRIC	L	LB	LD	LL	M	N	P	S	T
63	4	8.5	12.5	63	7	7X9.5	1-M20X1.5	279.5	194	95.5	101	75	60	90	M5	2.5
71	5	11	16	71	8	7X11	1-M20X1.5	300.5	215	110.5	101	85	70	105	M6	3
80	6	15.5	21.5	80	8	10X14	1-M25X1.5	345.5	250	115	101	100	80	120	M6	3
90S	8	20	27	90	10	10X14	1-M25X1.5	388	275	145	109	115	95	140	M8	3.5
90L	8	20	27	90	10	10X14	1-M25X1.5	413	300	145	109	115	95	140	M8	3.5
100L	8	24	31	100	11	12X16	1-M32X1.5	461	338	148.5	109	130	110	160	M8	3.5
112M	8	24	31	112	12	12X16	2-M32X1.5	484	334	154	117.5	130	110	160	M8	3.5
132S	10	33	41	132	15	12X16	2-M32X1.5	565	395	180	117.5	165	130	200	M8	4
132M	10	33	41	132	15	12X16	2-M32X1.5	608.5	433	180	117.5	165	130	200	M8	4

## 安装位置和尺寸图 Mounting position & Dimension

YVF63-160-B35

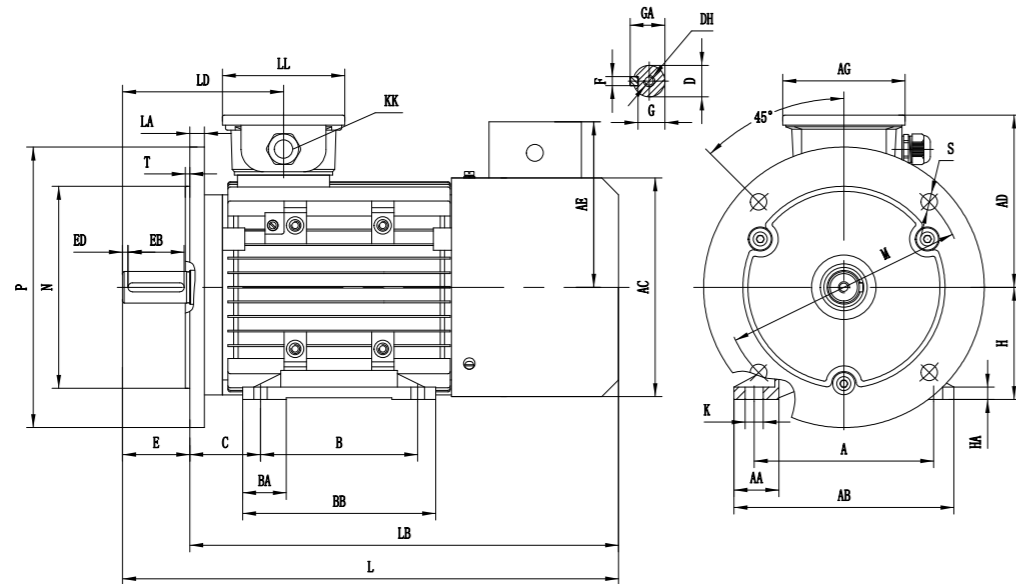

型号 TYPE	极数 POLE	A	AA	AB	AC	AD	AE	AG	B	BA	BB	C	D	DH	E	EB	ED
63	2,4,6	100	24	123	120	102	110	101	80	25.5	100	40	11	M4×12	23	16	3.5
71	2,4,6	112	26	138	136	109	118	101	90	27.5	110	45	14	M5×12	30	25	2.5
80	2,4,6,8	125	35	157	158	129	129	101	100	31	125	50	19	M6×16	40	30	5
90S	2,4,6,8	140	37	173	175	140	137.5	109	100	31.5	125	56	24	M8×19	50	40	5
90L	2,4,6,8	140	37	173	175	140	137.5	109	125	31.5	150	56	24	M8×19	50	40	5
100L	2,4,6,8	160	40	196	198	156	149	109	140	39	172	63	28	M10×22	60	50	5
112M	2,4,6,8	190	40	227	230	176	165	117.5	140	43	180	70	28	M10×22	60	50	5
132S	2,4,6,8	216	51	262	258	188	179	117.5	140	46	186	89	38	M12×28	80	65	7.5
132M	4,6,8	216	51	262	258	188	179	117.5	178	46	224	89	38	M12×28	80	65	7.5
160M	2,4,6,8	254	65	314	314	251	207	162	210	-	260	108	42	M16×36	110	90	10
160L	2,4,6,8	254	65	314	314	251	207	162	254	-	304	108	42	M16×36	110	90	10

型号 TYPE	F	G	GA	H	HA	K	KK	L	LA	LB	LD	LL	M	N	P	S	T
63	4	8.5	12.5	63	7	7×9.5	1-M20×1.5	279.5	10	194	95.5	101	115	95	140	10	3
71	5	11	16	71	8	7×11	1-M20×1.5	300.5	10	215	110.5	101	130	110	160	10	3.5
80	6	15.5	21.5	80	8	10×14	1-M25×1.5	345.5	12	250	115	101	165	130	200	12	3.5
90S	8	20	27	90	10	10×14	1-M25×1.5	388	12	275	145	109	165	130	200	12	3.5
90L	8	20	27	90	10	10×14	1-M25×1.5	413	12	300	145	109	165	130	200	12	3.5
100L	8	24	31	100	11	12×16	1-M32×1.5	461	13	338	148.5	109	215	180	250	14.5	4
112M	8	24	31	112	12	12×16	2-M32×1.5	484	14	334	154	117.5	215	180	250	14.5	4
132S	10	33	41	132	15	12×16	2-M32×1.5	565	14	395	180	117.5	265	230	300	14.5	4
132M	10	33	41	132	15	12×16	2-M32×1.5	608.5	14	433	180	117.5	265	230	300	14.5	4
160M	12	37	45	160	20	4-Φ14.5	2-M40×1.5	703.5	15	498	256	152	300	250	350	18.5	5
160L	12	37	45	160	20	4-Φ14.5	2-M40×1.5	747.5	15	542	256	152	300	250	350	18.5	5

注:表格内白底部分电机外壳材质为铝壳, 灰底部分电机外壳材质为铁壳