

版号：XG-B-06-2025/08-A-500

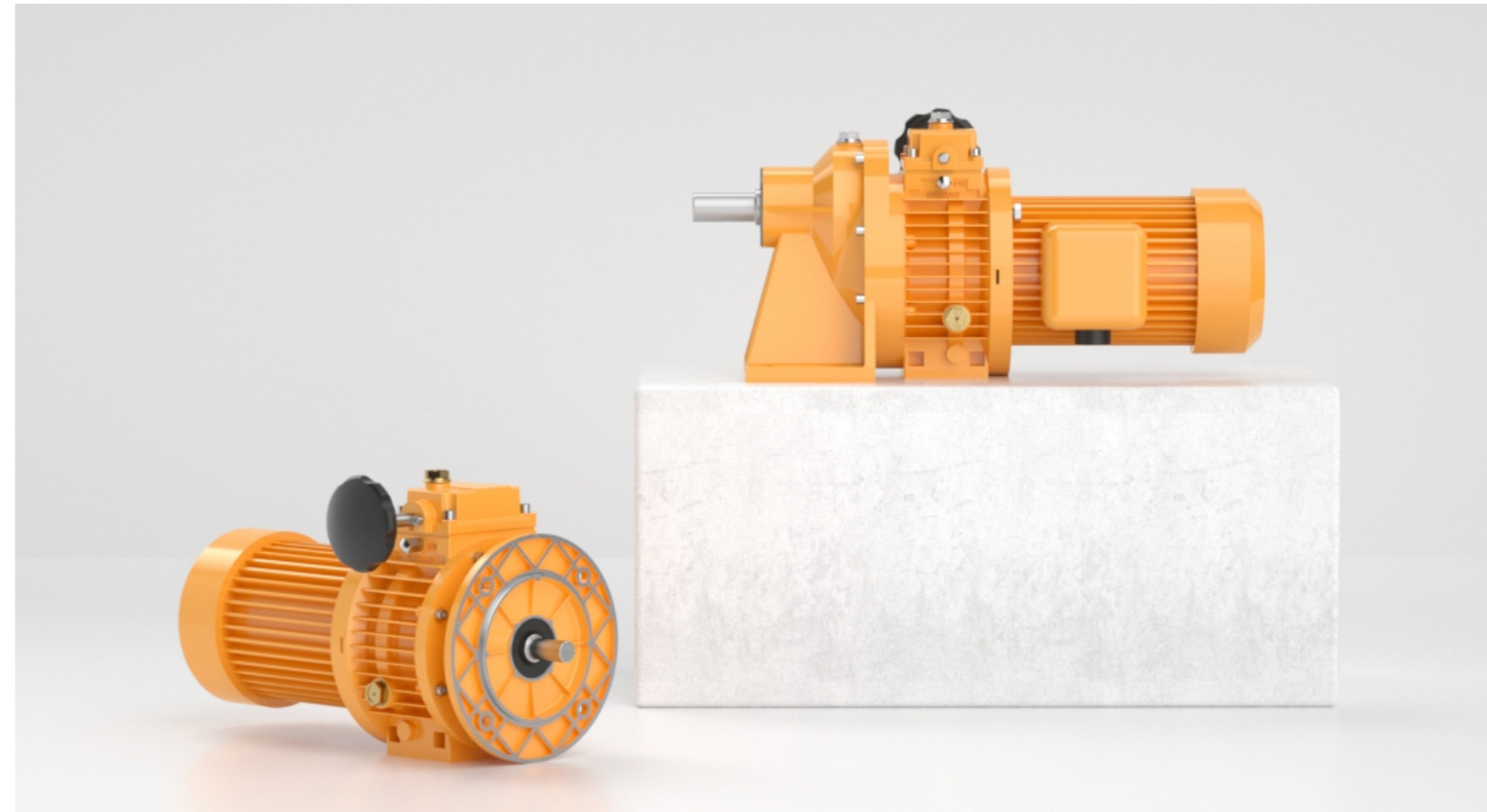

JWB-X系列无级变速器

JWB-X SERIES VARIATOR

动静之间 · 唯简不凡



星光传动官方网站



星光传动官方微信

广东星光传动股份有限公司

GUANGDONG STARSHINE DRIVE CO., LTD.

广东省佛山市三水区白坭镇汇金工业城 10 号
ADD: NO.10,Huijin Industrial park, Baini Town,Sanshui district,Foshan,Guangdong,China

HTTP://www.xgcd.cn 中文域名: 星光传动 . 网址
TEL: 400 850 5665 FAX:0757-66639837/838
E-MAIL:xg-sales@xgcd.cn



广东星光传动股份有限公司前身是一家创建于1965年的国有军工企业——国营星光工模具厂，公司在追求全体员工物质和精神双重幸福的同时，以行业领先的减变速机应用技术，驱动全球工业革新为使命，建设觉悟型组织，成为服务全球的幸福企业为愿景。

公司技术力量雄厚，现有员工420余人，其中工程技术人员40多名，和各种先进的加工制造和检测设备，依托省级工程技术研究中心、减速机产品试验室和现代化研发和生产基地，为高端减变速机产品的行业应用开发和服务提供了良好的发展基础。

公司主导产品有：NCJ系列齿轮减速机、R/S/K/F系列高精度齿轮减速机、RV系列蜗杆减速器、SNKG系列齿轮减速机、JWB-X系列机械无级变速器、B/JXJ系列摆线针轮减速机、SCK系列准双曲面齿轮减速机等七大系列产品可供选用，广泛服务于陶瓷、纺织、玻璃、木工、高压开关、食品饮料、包装印刷、仓储物流、起重运输等装备制造和应用行业，专为中高端用户提供专业的产品和服务。产品畅销国内，远销欧美、中东、东南亚等20多个国家和地区。

在未来的发展中，星光传动聚焦客户需求，提供有竞争力的传动解决方案，持续为客户创造价值，打造高端制造业和终端用户“替代进口、升级换代”的首选品牌！

动静之间，唯简不凡；携手同行，星光灿烂！

Guangdong Starshine Drive Co.,Ltd, the predecessor was a state-owned military mould enterprise which established in 1965. While pursuing the spiritual and material happiness of all employees, With the Mission "with industry-leading reduction and transmission technology to drive industrial renewal" and Vision "Build a conscious organization, become a happy enterprise serving the world".

Starshine has a strong technical force with over 400 employees at present, including over 40 engineering technicians, and kinds of advanced processing machines and testing equipment. Thanks to the Provincial Engineering Technology Research Center, the speed reducer product laboratory, the modern R&D and production base, that make Starshine has a good foundation to develop and service for high-end speed reducers.

Our main products include: helical geared motor, worm gearboxes, planetary gearboxes, speed variators, cycloidal gearboxes, helical-hypoid gearboxes, which widely used in ceramic industry, glass industry, woodworking machinery, high voltage switch, food & beverage, packaging & printing, Storage & logistics, hoisting & transportation facilities...etc, Starshine technically provide the professional product & service for the medium and high-end customers, and our gearboxes are best-selling in both domestic and abroad market, such as Europe, North America, South America, Middle East, South Asia, Southeast Asia, Africa...etc more than 20 countries and regions.

In future, Starshine will hold the business creed of "serving customer, diligence & simplicity, self-criticism, innovation, honesty, teamwork", and take "authenticity, altruism, openness, innovation, responsibility, collaboration" as core values. Focus on customers' requirements and provide them the competitive transmission solution and create value for them constantly, and create a preferred brand of replacing import products and upgrading continuously for the end users.

Between Dynamic and Static, Simple is Extraordinary, let's go forward hand in hand and make a brilliant future!

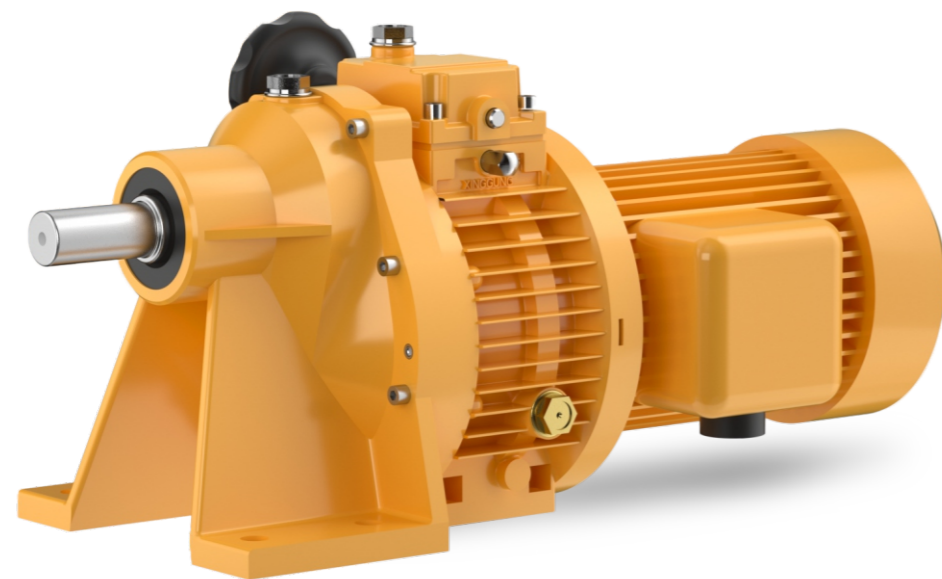

JWB-X系列无级变速器
 JWB-X SERIES VARIATOR

目录

CONTENT

国之星光

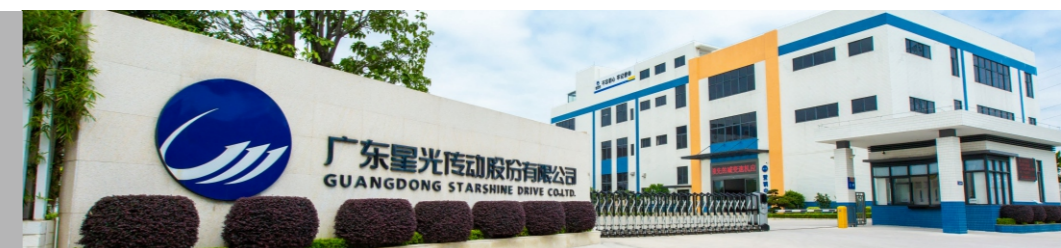

产品简介	01	安装形式	07
Product introduction	01	Installation pattern	07
零件爆炸图及名称	02	基本机型尺寸表	08-09
Exploded view & name of parts	02	Torque Arm	08-09
选型及订货指南	03	一级齿轮减速器尺寸表	10-11
Guide for selection & ordering	03	Motor thermal box position	10-11
电机接线盒位置	03	二级齿轮减速器尺寸表	12-14
Motor thermal box position	03	Product installation dimensions	12-14
使用注意事项	04	三级齿轮减速器尺寸表	15-16
Attention of using	04	Gear unit selection tables	15-16
型号表示法	05	润滑油	17
Model designation	05	Lubricating oil type	17
参数表	06	一般故障及排除法	18
Selectiontable	06	Failure and solution	18

产品简介 Introduction

行星锥盘摩擦无级变速器(以下简称无级变速器),是目前国内外一种先进的无级变速装置。星光JWB-X系列无级变速器是公司在消化吸收国内外先进技术基础上,国内最早自主研发开发的新型无级变速器。产品执行标准JB/T6950-93《行星锥盘无级变速器》,具有结构简单、性能可靠、变速范围大(输出转速的最高速与最低速之比5)调整灵活可靠、体积小、噪音低、使用维护方便等特点,适用于连续工作运转,且能在带负载条件下按需要调节速度,最适应工艺参数多变或连续变化的要求。因而可作一切行业生产自动线的动力传动装置及科研单位试验设备的无级变速机构,对陶瓷,饮料、食品、电子、制革、化工纺织、木工等行业生产自动线尤为适用。

Planetary cone disk friction continuously variable transmission (hereinafter referred to as continuously variable transmission) is an advanced continuously variable transmission device at home and abroad. Starlight JWB-X series continuously variable transmission is the first self-developed new continuously variable transmission based on the company's absorption of advanced technology at home and abroad. JB/T6950-93 Planetary cone-disk CVT, the utility model has the advantages of simple structure, reliable performance, large speed range (the ratio of the highest speed to the lowest speed of the output speed 5), flexible and reliable adjustment, small volume, low noise, convenient operation and maintenance, etc., it is suitable for continuous operation, and can adjust the speed according to the need under the condition of load. It is most suitable for the requirement of changeable or continuous process parameters. Therefore, it can be used as a stepless speed-changing mechanism for power transmission devices and test equipment of scientific research units in all industries, the automatic production line is especially suitable for the industries of beverage, beverage, electronics, leather, chemical, textile, wood and so on.

变速原理 How it works

带锥度的摩擦轮,外图夹在底环与调速凸轮之间,里圈在主动轮及压环之间,主动轮与压环由碟簧压紧当主动轮由电机带动时摩擦轮就作纯滚动由于底环与调速凸轮不动,因此摩擦轮在自动的同时绕支架作公转运动,通过摩擦轮的轴及滑块从而带动支架转动。当转动调速首轮(图中未表示)调速凸轮就改变角向位置,并通过凸轮形面使调速凸轮产生轴向移动从而改变调速凸轮与底环之间的间隙,迫使摩擦轮作径向移动,进而改变摩擦轮的接触半径。当间隙增大时,摩擦轮外移,公转速度变慢,当间隙减小时,摩擦轮内移,公转速度变快,即可达到无级变速的目的只要将手轮调到一定位置,摩擦轮就可均匀的处于某一相应的位置上,输出轴就能得到所需要的稳定转速。

Friction wheel with taper, outer drawing sandwiched between bottom ring and speed regulating cam, inner ring between driving wheel and pressing ring, the driving wheel and the pressing ring are pressed by the disc spring when the driving wheel is driven by a motor, the friction wheel rolls purely, the shaft and the slider of the friction wheel drive the bracket to rotate. When the first wheel (not shown in the picture) is rotated, the governing cam changes the yaw position and causes the governing cam to move axially through the cam profile, thus changing the clearance between the governing cam and the bottom ring, the friction wheel is forced to move radially, and then the contact radius of the friction wheel is changed. When the gap increases, the friction wheel moves outward and the revolution speed slows down. When the gap decreases, the friction wheel moves inward and the revolution speed becomes faster, the friction wheel can be evenly placed in a corresponding position, the output shaft can be required to obtain a stable speed.

零件爆炸图及名称 Exploded view & name of parts

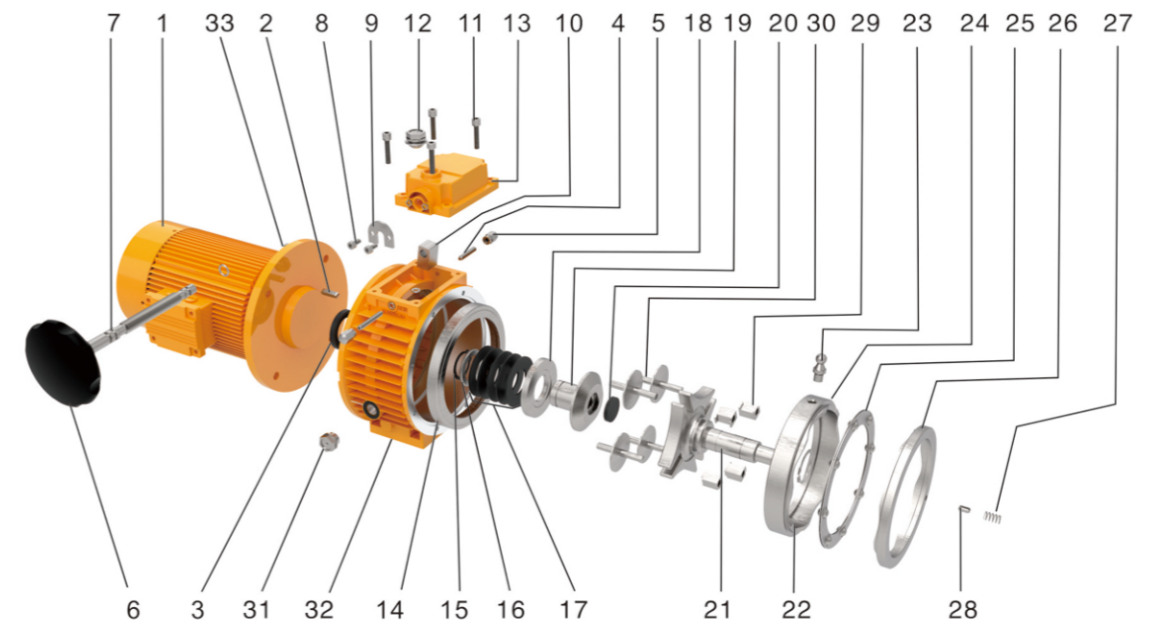

序号 No.	名称 Description	机座号BASE NO.					
		01	02	03	04	05	06
		数量Quantity					
1	电机 Electric motor	1	1	1	1	1	1
2	键 Motorspindle key	1	1	1	1	1	1
3	油封 Oil seal	1	1	1	1	1	1
4	紧定螺钉 Stop stud	2	2	2	2	2	2
5	螺母 Stop nut	2	2	2	2	2	2
6	调速手轮组件 Hand wheel	1	1	1	1	1	1
7	O型圈 O-ring	1	1	1	1	0	0
8	螺钉 Stud	2	2	2	2	2	2
9	挡块 Stop-washer	1	1	1	1	1	1
10	拨块 Contrl-socket	1	1	1	1	1	1
11	螺钉 Stud	4	4	4	4	4	4
12	通气油塞 Oil breather	1	1	1	1	1	1
13	调速盒 Speed contrlcover	1	1	1	1	1	1
14	底环 Fixed-ring	1	1	1	1	1	1
15	轴用挡圈 Circlip	1	1	1	1	1	1
16	挡圈套 Stop ring	1	1	1	1	1	1
17	蝶形弹簧 Dish spring	3	3	5	5	5	7

序号 No.	名称 Description	机座号BASE NO.					
		01	02	03	04	05	06
		数量Quantity					
18	压环 Press ring	1	1	1	1	1	1
19	主动轮 Drive	1	1	1	1	1	1
20	闷盖 Bore seal	1	1	1	1	1	1
21	支架 Carrier	1	1	1	1	1	1
22	轴用挡圈 Circlip	1	1	1	1	1	1
23	拨杆 Control-lever	1	1	1	1	1	1
24	调速凸轮 Seep control cam	1	1	1	1	1	1
25	滚珠组件 Ball-ring combiner	1	1	1	1	1	1
26	固定凸轮 Fixed cam	1	1	1	1	1	1
27	弹簧 Coilsring	3	6	6	6	10	8
28	销 Pin	1	1	1	1	1	1
29	滑块 Bushing	3	4	4	5	6	6
30	摩擦轮 Planet wheel	3	4	4	5	6	6
31	油镜 Oil-washing lens	2	2	2	2	2	2
32	中座 Variator casting	1	1	1	1	1	1
33	螺栓 Stud	4	4	4	4	4	4

选型及订货指南
Guide for selection & ordering

- 订货时请根据使用需要的转速和转矩，合理选择机型，请写明机型号，如果用特殊电机，请注明清楚并于本公司协商：为充分显示本机型的优良特性，常用转速应选择变速器调速范围的中间位置。例：常用转速在100-200/min，则应选取变速器的调速范围为40-200r/min，即JWB-X***_40*并注意变速器参数表给出的输出转矩。如JWB-X0.75B-40D给出的输出转矩是50-25N·m是指40r/min时允许输出转矩50N·m，200r/min时允许输出转矩25N·m 转速越快 允许输出转矩越低，如不注意选择会造成输出转矩不够，产生打滑现象。
- 订货时请尽量选用本厂标准产品，如有特殊要求请在签订合同时详细说明，如电机出线盒与调速手轮的位置，安装型式和要求输出转速等。
- 我厂有专业设计和制造队伍，可承接特殊规格产品的订货，并可为用户专门设计。
- 本机型调速部使用专用无级变速器油Ub-3，本机出厂时以随机机装好，开机即可使用。
- 本公司负责维修指导。
- When ordering please choose the suitable type and specify it according to the required speed and torque. For special motors please specify and consult with us. To realize the excellent characteristics of the variator usual speed value should be at the middle of the variable range. For example if the usual speed is 100-120r/min the variator should be chosen within the varying range 40-120r/min. e. JWB***40-D is 50-25N.m. This means the permissible output torque is 52N.m in case of 40r/min, the permissible output torque is 25N.m in case of 200r/min. The higher the speed the lower the output torque. Disregard for correct choice will cause skid faults resulting from lower output torque.
- when ordering it is recommended to choose the standard products listed in the catalogus. Fox special requirements please state the details in the contract such as the positions of the junction box in motor and the hand wheel the mounting position and the output speed etc. we own a professional design and manufacturing team, which is qualified to accept special orders and design particulars for customers.
- The speed-adjust parts of variator is lubricated by oil Ub-3. The products is filled with oil in the factory which can be used when turning on.
- We are responsible for offering maintenance guide.

电机接线盒位置（从电机风扇罩端向调速盒方向看）
Motor thermal box position (viewed speed control cover box from fan cowl of motor)

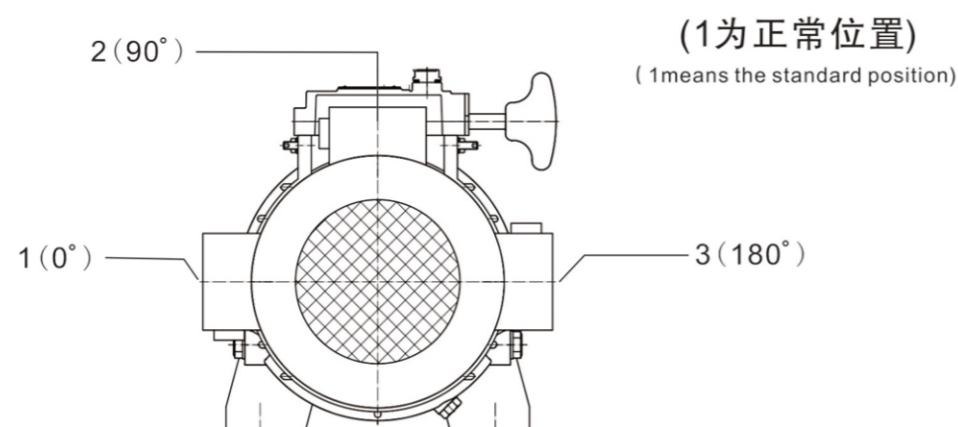

使用注意事项 Attention of using

- 本机适合连续工作，通过三相电动机换接任意二根相线，可以正向或反向运转。
- 选用本机时，应根据工作机械的扭矩来选取本机的扭矩，简易公式如下： $T_o = T_a \times K$ 本机输出扭矩 (N·m) T_a 工作机械需要的扭矩 (N·m) K 修正系数 (见下表)
- The variator is suitable for heavy duty. Running obverse or reverse is easy to be operated by exchanging any two phase lines of the three-phase motor.
- When choosing the variator its torque should be caoordance with load. Simple formula is as follows: $T_o = T_a \times K$ - ova-riator output torque (N·m) T_{a} load needing torque (N·m) K revise factor (see follwing table)

每天平均工作时间 Average working time per day	稳定的负荷和连续运转并没有正反向转动，惯性小 Steady load heavy duty No directional change Weak inertia	轻微冲击或间隙运动，或正反向转动，惯性适中 Light shock or interval Movement or directional Changr medium inertia	有较大的冲击并间隙运动，且有正反向转动，惯性大 Heavy shock and interval Movement directional change strong inertia
不足8小时 < 8 hours	1.0	1.3	1.7
不足8-16小时 < 8-16 hours	1.1	1.4	1.9
连续工作 heavy duty	1.2	1.5	2.0

- 检查本机标牌数据是否符合负载机械的需要。
- 首次换油时间为工作300小时，以后每隔1000小时换油，有注油孔加油至油镜中部，切勿过量。
- 减速部用锂基润滑脂作轴承及齿轮润滑，无需更换。
- 特别注意，调速手轮只能在开机后才能转动，按手轮上的快慢指向转动，严禁停机调速。
- 本机输出轴轴径公差为f6，安装皮带轮、齿轮或联轴节时，应利用轴头螺孔加垫圈用螺栓拧紧，严禁锤击。
- 特殊情况，不熟悉该机结构，不要随意拆卸变速器，以免影响变速器的传动精度，拆卸不当甚至造成摩擦轮飞出伤人，有一定的危险性，装配要经过培训才能进行。
- 下列情况容易损坏本机
 - ▲ 电源电压和接法与电机标牌规定不符
 - ▲ 三相开关保险丝有一相不通或接触不良
 - ▲ 超负荷运行
 - ▲ 电机风扇风道阻塞
 - ▲ 没有开机而转动手轮
 - ▲ 本机正常运动过程伸，应注意环境清洁，防止尘土，纤维，水，酸碱物质或其他杂物侵蚀机体
- Make sure that the parameters are marked on the variator which conform to load.
- The first oil pouring must be around 300 hours of working time, then pour oil per 1000 hours from oil pouring hole to the middle of oil-watchhubf lens and don't be excessively
- The shafts and gears of the reducer are lubricated with lithium bast grease they don't need lubricant maintenance
- Attention: The hand wheel only can be turned when the variator is working, according to the slow-quick direction marked on it. Turning the hand wheel is strictly prohibitttd while stopping
- The shaft-diaeme tolerance of the output shaft is f6. When installing the pulley and gear please use spindle noes, and the screw plus washer to bolet them up
- People must be traned and familiarized with the structure of the variator to demount it. If not, it will affect the transmission preeision. Remove planet wheel will hurt the disassembly operator
- The following cases might damage the variator:
 - ▲ Power is wrongly connected or not according to the nameplate on motor
 - ▲ One of the three-phase fuse is not or poorly connected
 - ▲ Running overload
 - ▲ The motor fans circumvoles is bocked
 - ▲ Turning hand wheel when stopping
- When running keep the working environment clean protect variator from dust fibres water acid alkali and any other debris

型号表示法 Model designation

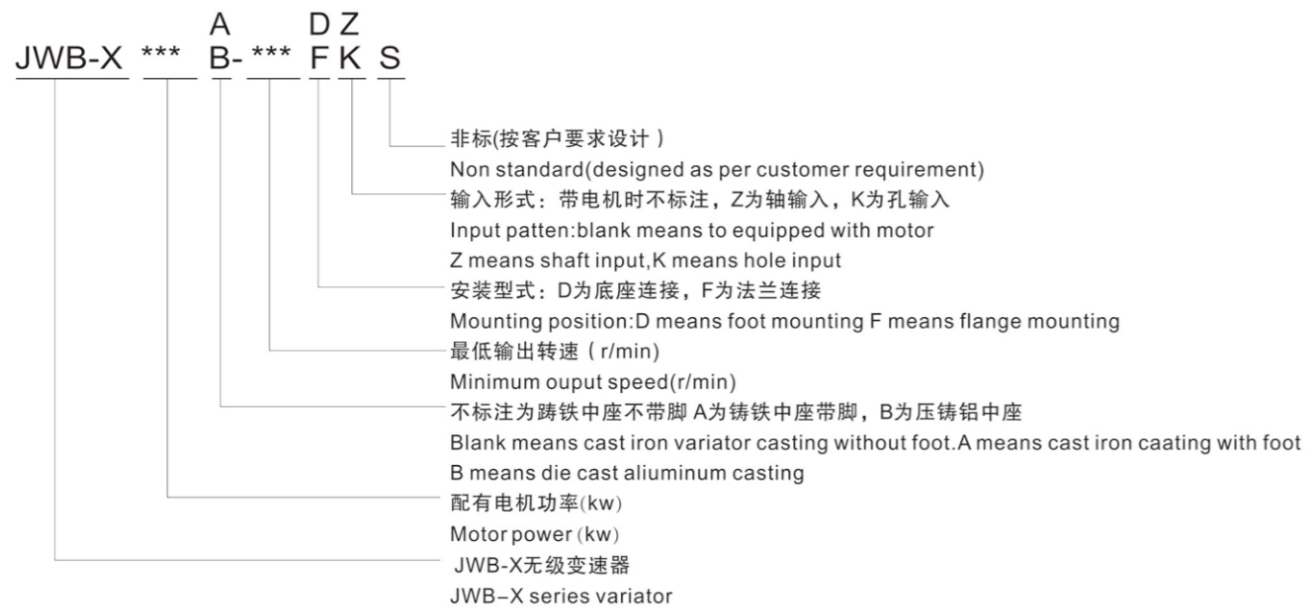

型号表示方式示例 Example

- JWB-X0.75B-40D表示: 无级变速器输入功率0.75kw, B为压铸铝中座型, 最低输出转速为40r/min, 最高输出转速为40*5=200r/min, D为底座连接。
- JWB-X0.37B-190F表示: 无级变速器输入功率0.37kw, B为压铸铝中座型, 最低输出转速为190r/min, 最高输出转速为190*5=950r/min, F为法兰连接。
- JWB-X0.37B-190FK表示: 无级变速器允许用户选用4极0.37Kw铝壳电机 (或最大输入功率0.37kw), B为压铸铝中座型, 此时的最低输出转速为190r/min,最高输出转速为190*5=950r/min K为孔输入 (出厂不带电机), F为法兰连接。
- JWB-X0.75A-190DZ表示: 无级变速器允许用户选用4极0.75kw电机 (或最大输入功率0.75kw), A表示铸铁中座带脚型, 此时的最低输出转速为190r/min最高输出转速为190*5=950r/min, D为底座连接, Z表示轴输入 (出厂不带电机)。
- JWB-X0.75B-40D:the input power of variator is 0.75kw; B means alumimium variator casting; minmum output speed is40r/min; maximum outputspeed is40*5=200r/min; D means foot mounting.
- JWB-X0.37B-190F:the input power of 0.37kw; B means aluminmium variator casting; minimum output speed is 190r/min; maximum output speedis 190*5=950r/min; F means flange mounting.
- JWB-X0.37B-190FK:0.37kw motor with 4 poles is allowed; B means alumimum variator casting; minimum output speed is190r/min; maximum outputspeed is 190*5=950r/min; K means hole input(without motor); F means flange mounting.
- JWB-X0.75A-190D; 0.75kw motor with 4 poles is allowed; A means cast iron variator casting with foot; minimum output speed is 190r/min; maximum output speed is 190*5=950r/min; D means foot mounting; Z means shaft input(without,motor).

参数表 Selection table

机座号 Base No	01	02		03		04		05			06		
电机输入功率 Input power	0.18	0.25	0.37	0.55	0.75	1.1	1.5	2.2	3	4	5.5	7.5	
电机级数 Poles	4极 (1400r/min) 4poles												
变速机型号 Variator Model	输出速度 Outputspeed	许用输出转矩 (N.m) Output torque allowed											
基本机型 Basic model	190-950	-	3.5-1.8	5.1-2.7	8-4	11-5.4	15.3-8	21-11	30.6-16	42-22	59-29	77-40	105-54
	190-760	2.5-1.6	--	--	--	--	--	--	--	--	--	--	--
一级齿轮 减速 Single stage Gear reducer	100-500	--	6.5-3.4	9.5-5	14.2-7.4	20-10	29.2-15	40-20	58-30	80-40	104-54	143-74	200-101
	80-400	--	8-4.2	12.3-6.2	17.5-9.3	25-12.5	37-18.5	50-25	71-37	100-50.5	130-67	180-93	245-126
	60-300	--	11-5.6	15.8-8.3	24.5-13	33.2-16.8	50-21.7	65-34	98-50	134-67.5	173-90	240-124	330-168
	40-200	--	16-8.4	24-12.5	35.4-18.5	50-25	73-37	100-50.5	147-74	200-101	256-135	380-190	490-253
二级齿轮 减速 Two-stage Gear reducer	30-150	--	--	--	--	--	--	--	186-100	267-132	356-176	490-242	668-330
	28-140	--	--	--	52-26	70-35.4	105-52	143-71	--	--	--	--	--
	25-125	--	25-13	39-20	--	--	--	--	--	--	--	--	--
	20-100	--	--	--	--	--	--	--	294-145	401-198	535-264	735-363	1002-495
	18-90	--	--	--	81-40	100-55	--	--	--	--	--	--	--
	15-75	--	42-22	65-32.6	--	--	196-97	255-132	--	--	--	--	--
	13-65	--	--	--	113-56	150-76	--	--	--	--	--	--	--
	9-45	--	65-37	105-54	--	230-140	--	--	--	--	--	--	--
三级齿轮 减速 Three-stage Gear reducer	8-40	--	--	--	182-91	250-124	--	--	--	--	--	--	--
	6.5-32.5	--	--	--	225-112	300-152	--	--	--	--	--	--	--
	4.7-23.5	--	138-69	204-102	292-150	426-207	603-303	795-413	--	--	--	--	--
	2-10	--	238-96	258-141	426-225	596-289	787-420	795-429	--	--	--	--	--

注: 电机输入功率kw, 输出转速r/min
 Not: input power unit:kw,output speed unit:r/min

安装形式 Installation pattern

△ 通气油塞 (加油孔) Oil breather(vent plug)
○ 油镜 Oil level plug

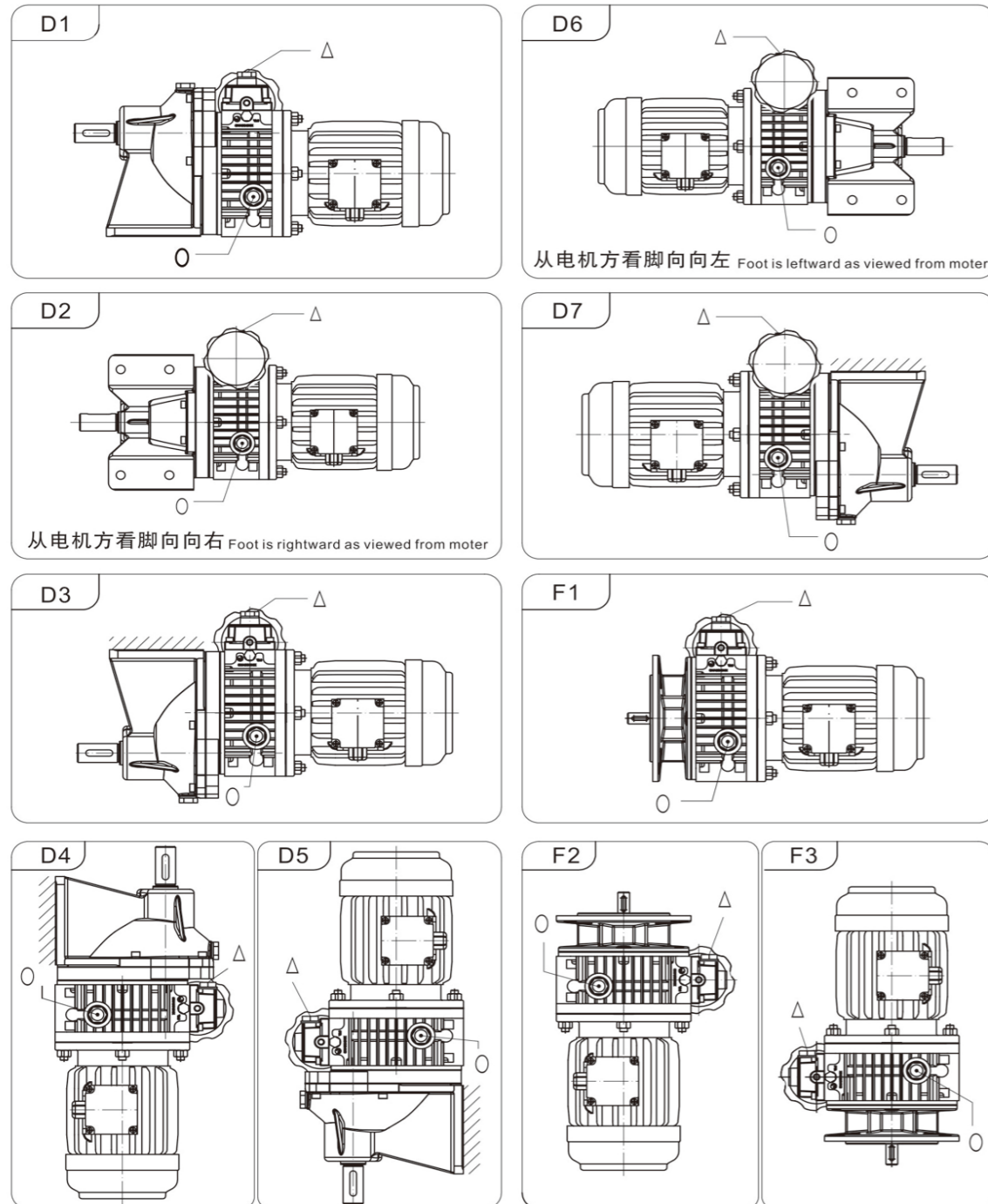

基本机型 (190D/F) 参数、尺寸表
Selection & dimensions of basic model

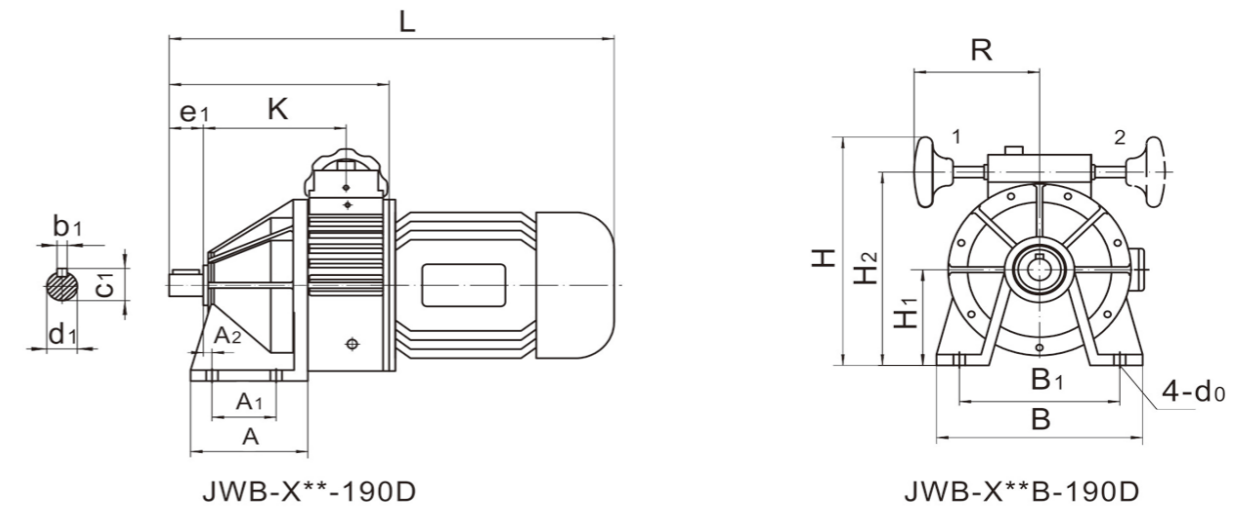

型号 Model	机座号 Base No.	整体安装尺寸 Mounting dimension				输出轴尺寸 Output shaft dimension			
		A ₁	A ₂	d ₀	B ₁	d ₁	b ₁	c ₁	e ₁
JWB-X**-190D	01	25	1.2	9	95	11f6	4	12.5	30
	02	55	6	10	150	14f6	5	16	40
	03	66	6	12	165	24f6	8	27	50
	04	75	18	14.5	185	28f6	8	31	60
JWB-X**B-190D	01	25	1	9	95	11f6	4	12.5	30
	02	55	6	10	150	14f6	5	16	40
	03	66	6	12	165	24f6	8	27	50
	04	75	18	14.5	185	28f6	8	31	60

型号 Model	机座号 Base No.	外形尺寸 Outline dimensions								净重 N · W (kg)	
		H	H ₁	H ₂	L	L ₂	A	B	K		R
JWB-X**-190D	01	189	70	145	356	147	55	120	82	125	15
	02	211	80	168	437	202	90	190	121	125	22
	03	254	105	212	512	247	118	212	145	133	38
	04	291	125	252	615	320	141	235	187	142	61
JWB-X**B-190D	01	190	70	148	365	156	55	120	82	125	10
	02	211	80	168	440	205	90	190	121	125	17
	03	255	105	212	517	252	118	212	150	133	26
	04	291	125	252	627	322	141	235	187	146	53

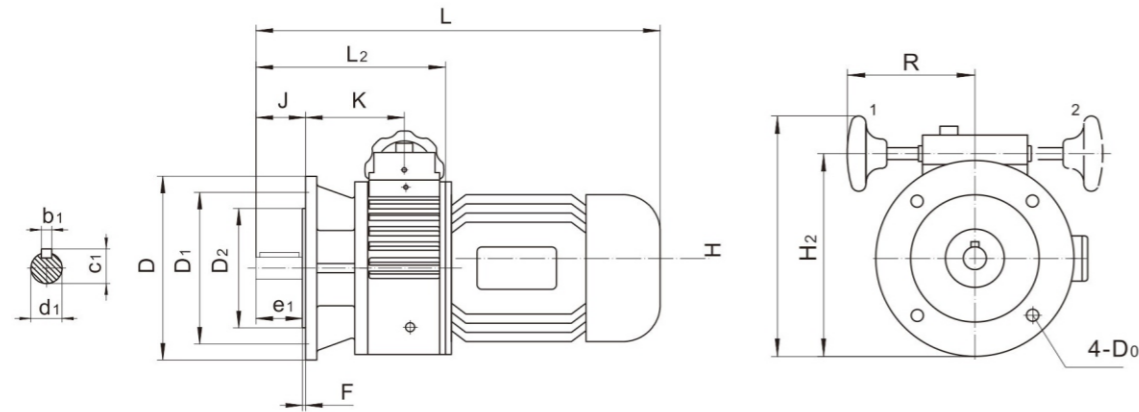
基本机型 (190D/F) 参数、尺寸表
 Selection & dimensions of basic model

JWB-X**-190F

JWB-X**B-190F

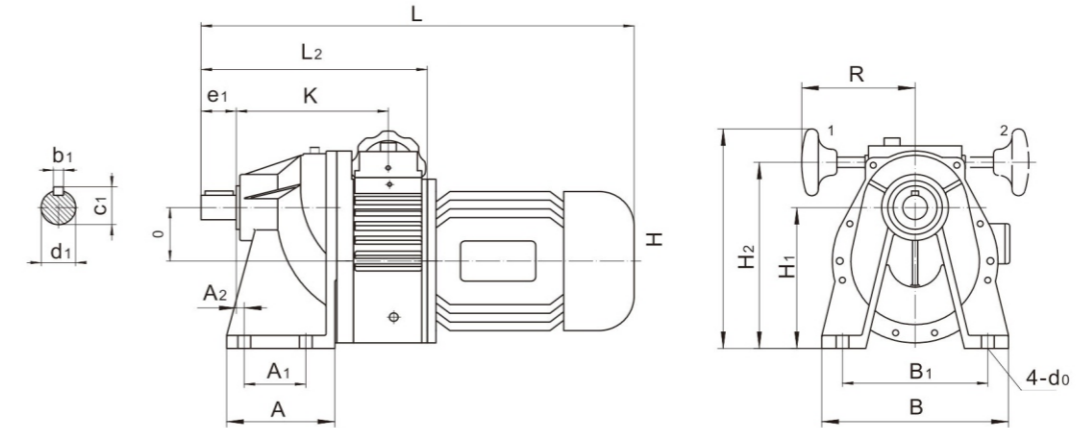
一级齿轮减速 (40-100D/F) 参数/尺寸
 Selection & dimensions for single stage gear reducer

JWB-X**D

JWB-X**B-**D

型号 Model	机座号 Base No.	整体安装尺寸 Mounting dimension					输出轴尺寸 Output shaft dimension			
		D ₁	D ₂	D ₀	J	F	d ₁	b ₁	c ₁	e ₁
JWB-X**-190F	01	115	95	10	31	3	11f6	4	12.5	30
	02	130	110	10	43.5	3.5	14f6	5	16	40
	03	165	130	12.5	54.5	3.5	24f6	8	27	51
	04	215	180	14.5	61	4	28f6	8	31	60
	05	265	230	15	80	4	38f6	10	41	76
JWB-X**B-190F	01	115	95	10	31	3	11f6	4	12.5	28
	02	130	110	9	30	3.5	14f6	5	16	30
	03	165	130	11	40	3.5	19f6	6	21.5	40
	04	215	180	14.5	61	4	28f6	8	31	60

型号 Model	机座号 Base No.	整体安装尺寸 Mounting dimension				输出轴尺寸 Output shaft dimension				
		A ₁	A ₂	d ₀	B ₁	O	d ₁	b ₁	c ₁	e ₁
JWB-X**D	02	64	4	12	148	51	24f6	8	27	50
	03	70	10	14.5	165	61.5	28f6	8	31	60
	04	85	0	14.5	186	78	38f6	10	41	70
	05	100	0	14.5	201	81	48f6	12	47	80
JWB-X**B-**D	02	64	4	12	148	51	24f6	8	27	50
	03	70	10	14.5	165	61.5	28f6	8	31	60
	04	85	0	14.5	186	78	38f6	10	41	70
	05	100	0	14.5	201	81	48f6	12	47	80

型号 Model	机座号 Base No.	外形尺寸 Outline dimensions							净重 N·W (kg)
		H	H ₂	L	L ₂	D	K	R	
JWB-X**-190F	01	189	146	354	147	140	81	125	15
	02	210	166	393	168	160	86	425	22
	03	250	209	475	212	200	107	133	38
	04	291	252	565	261	250	127	140	61
	05	356	313	670	319	300	151	191	134
JWB-X**B-190F	01	190	148	365	156	140	81	125	10
	02	210	166	390	154	160	86	125	20
	03	250	207	445	182	200	92	133	24
	04	291	252	567	265	250	127	140	53

型号 Model	机座号 Base No.	外形尺寸 Outline dimensions								净重 N·W (kg)	
		H	H ₁	H ₂	L	L ₂	A	B	K		R
JWB-X**D	02	211	131	169	469	244	112	190	155	125	25
	03	251	162	208	542	287	123	212	176	133	13
	04	285	195	244	639	341	155	240	198	140	70
	05	356	252	313	826	425	207	291	252	191	134
JWB-X**B-**D	02	211	131	169	473	248	112	190	155	125	23
	03	251	162	208	548	293	123	212	176	133	29
	04	283	195	244	638	343	155	240	198	142	62
	05	356	252	313	826	425	207	291	252	191	134

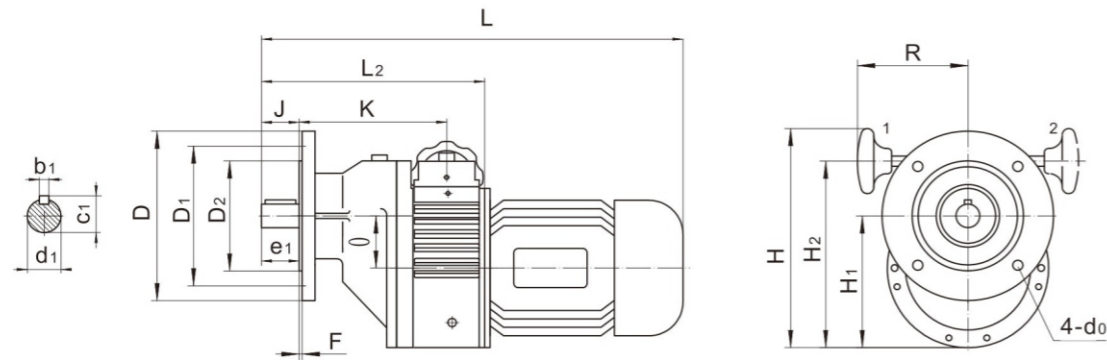
一级齿轮减速(40-100D/F)参数/尺寸
 Selection & dimensions for single stage gear reducer

JWB-X**-**F

JWB-X**B**-**F

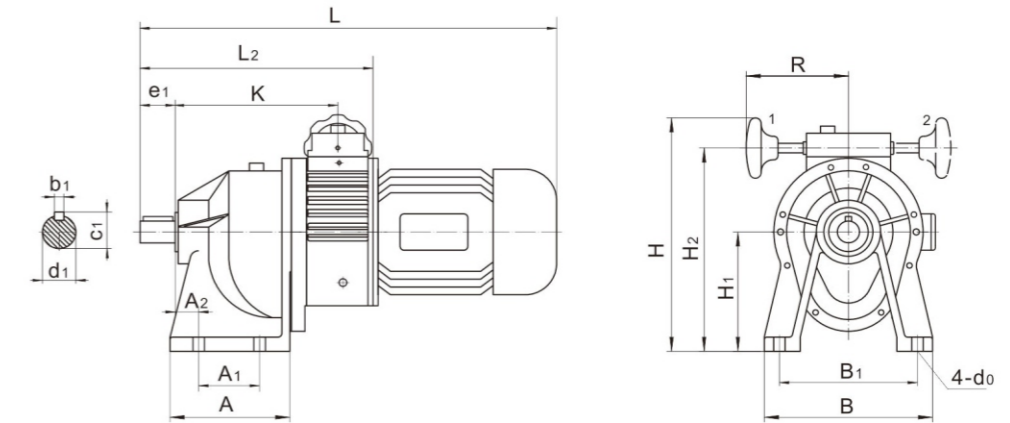
二级齿轮减速(6.5-30D/F)参数/尺寸
 Selection & dimensions for two-stage gear reducer

JWB-X**-**D

JWB-X**B**-**D

型号 Model	机座号 Base No.	整体安装尺寸 Mounting dimension					输出轴尺寸 Output shaft dimension				
		D ₁	D ₂	d ₀	J	F	O	d ₁	b ₁	c ₁	e ₁
JWB-X**-**F	02	130	110	10.5	54	4	51	24f6	8	27	50
	03	165	130	12	65	3.5	61.5	28f6	8	31	63
	04	215	180	14.5	72	4.5	78	38f6	10	41	70
JWB-X**B**-**F	02	130	110	10.5	54	4	51	24f6	8	27	50
	03	165	130	12	65	3.5	61.5	28f6	8	31	63
	04	215	180	14.5	72	4.5	78	38f6	10	41	70

型号 Model	机座号 Base No.	整体安装尺寸 Mounting dimension				输出轴尺寸 Output shaft dimension			
		A ₁	A ₂	d ₀	B ₁	d ₁	b ₁	c ₁	e ₁
JWB-X**-**D	02	85	18	12	150	28f6	8	31	55
	03	106	26	14.5	174	28f6	8	31	60
	04	130	27	14.5	200	38f6	10	41	70
JWB-X**B**-**D	02	85	18	12	150	28f6	8	31	55
	03	106	26	14.5	174	28f6	8	31	60
	04	130	27	14.5	200	38f6	10	41	70
JWB-X0.55B/X0.75B-6.5D	03	106	26	14.5	174	28f6/30f6	8	31	60
JWB-X0.25-25DS	02	74.5	13	10	105	20f6	6	22.5	38.5

型号 Model	机座号 Base No.	外形尺寸 Outline dimensions								净重 N·W (kg)
		H	H ₁	H ₂	L	L ₂	D	K	R	
JWB-X**-**F	02	209	129	166	473	248	150	151	125	25
	03	263	163	209	542	287	200	171	133	43
	04	322	192	241	636	341	250	197	142	70
JWB-X**B**-**F	02	211	131	169	473	248	150	151	125	23
	03	262	162	207	548	293	200	171	133	29
	04	322	192	241	639	343	250	197	142	62

型号 Model	机座号 Base No.	外形尺寸 Outline dimensions								净重 N·W (kg)	
		H	H ₁	H ₂	L	L ₂	A	B	K		R
JWB-X**-**D	02	242	110	199	520	295	142	190	201	125	29
	03	302	152	259	600	344	168	212	235	133	49
	04	337	172	299	702	407	185	255	266	140	77
JWB-X**B**-**D	02	242	110	199	524	299	142	190	201	125	25
	03	302	152	259	605	350	168	212	235	133	35
	04	337	172	299	704	412	185	255	266	140	69
JWB-X0.55B/X0.75B-6.5D	03	302	152	259	605	350	168	212	235	133	35
JWB-X0.25-25DS	02	210	80	168	446	253.2	119	128	158	125	25

二级齿轮减速(6.5-30D/F)参数/尺寸
Selection & dimensions for two-stage gear reducer

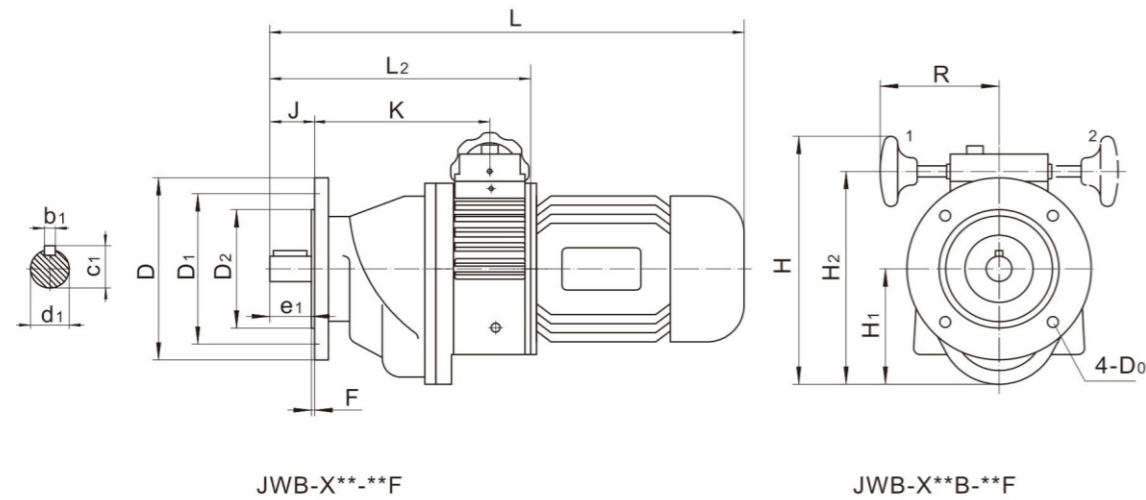

型号 Model	机座号 Base No.	整体安装尺寸 Mounting dimension					输出轴尺寸 Output shaft dimension			
		D ₁	D ₂	D ₀	J	F	d ₁	b ₁	c ₁	e ₁
JWB-X**F	02	130	110	12	58	4	28f6	8	31	54
	03	130	110	12	67	3.5	28f6	8	31	65
	04	215	180	14.5	72	4	38f6	10	41	68
JWB-X**B**F	02	130	110	10.5	57	4	28f6	8	31	53
	03	130	110	12	67	4	28f6	8	31	63
	04	215	180	14.5	72	4	38f6	10	41	68
JWB-X0.55B/X0.75B-6.5F	03	165	130	12	63	3.5	28f6/30f6	8	33	60
JWB-X0.25-25FS	02	110	86	9	44	4	20f6	6	22.5	40
JWB-X1.5/1.5B-21F	04	165	130	12	61.5	3.5	30f6	8	33	58
JWB-X2/2.4(2/2.4B)-28/56F	04	215	180	4-Φ14	70	4.5	38f6	10	41	66
JWB-X2/2.4(2/2.4B)-28/56FS	04	165	130	6-Φ14	70	4.5	30f6	8	33	66

二级齿轮减速(6.5-30D/F)参数/尺寸
Selection & dimensions for two-stage gear reducer

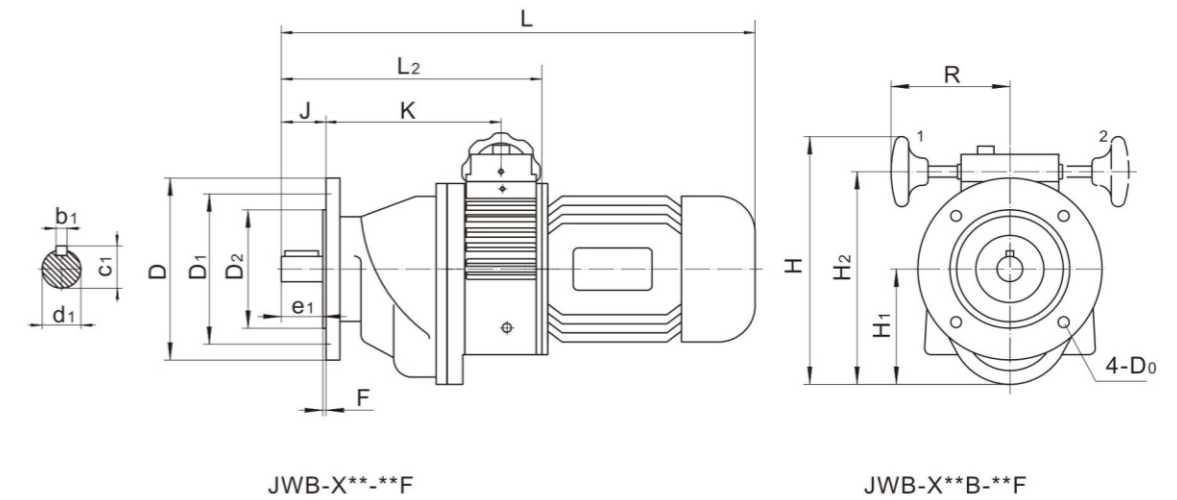

型号 Model	机座号 Base No.	外形尺寸 Outline dimensions								净重 N·W (kg)
		H	H ₁	H ₂	L	L ₂	D	K	R	
JWB-X**F	02	238	108	196	520	295	150	199	125	29
	03	277	127	234	599	344	160	227	133	49
	04	334	168	295	702	407	250	263	140	77
JWB-X**B**F	02	238	108	196	524	299	150	199	125	25.5
	03	277	127	234	601	346	160	231	133	35
	04	334	168	295	704	412	250	263	140	69
JWB-X0.55B/X0.75B-6.5F	03	277	127	234	605	350	200	231	133	35
JWB-X0.25-25FS	02	210	80	168	446	253.2	136	158	105	25
JWB-X1.5/1.5B-21F	04	280	115	241	655/657	360/362	200	225	142	70
JWB-X2/2.4(2/2.4B)-28/56F	04	334	168	295	688/690	363/365	250	222	142	80
JWB-X2/2.4(2/2.4B)-28/56FS	04	334	168	295	688/690	363/365	200	222	142	80

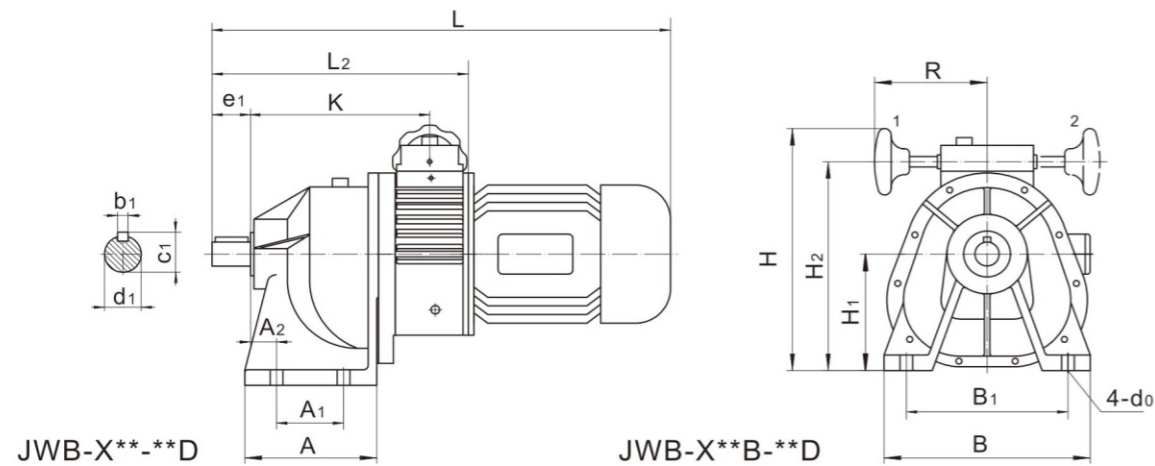
三级齿轮减速(2-4.7D/F)参数/尺寸
 Technical characteristics & dimensions for three-stage gear reducer

型号 Model	机座号 Base No.	整体安装尺寸 Mounting dimension				输出轴尺寸 Output shaft dimension				
		A ₁	A ₂	d ₀	B ₁	d ₁	b ₁	c ₁	e ₁	
JWB-X**-**D	02	100	33	12	150	32f6	10	35	60	
	03	120	39	14.5	185	38f6	10	41	70	
	04	160	25	14.5	210	42f6	12	45	80	
JWB-X**B-**D	02	100	33	12	150	32f6	10	35	60	
	03	120	39	14.5	185	38f6	10	41	70	
	04	160	25	14.5	210	42f6	12	45	80	

型号 Model	机座号 Base No.	外形尺寸 Outline dimensions									净重 N·W (kg)
		H	H ₁	H ₂	L	L ₂	A	B	K	R	
JWB-X**-**D	02	241	110	199	557	332	168	190	233	125	33
	03	285	135	242	651	396	193	236	271	133	60
	04	331	165	292	759	464	240	262	311	140	85
JWB-X**B-**D	02	241	110	199	560	335	168	190	233	125	30
	03	285	135	242	651	396	193	236	271	133	46
	04	338	165	292	761	468	240	262	312	140	77

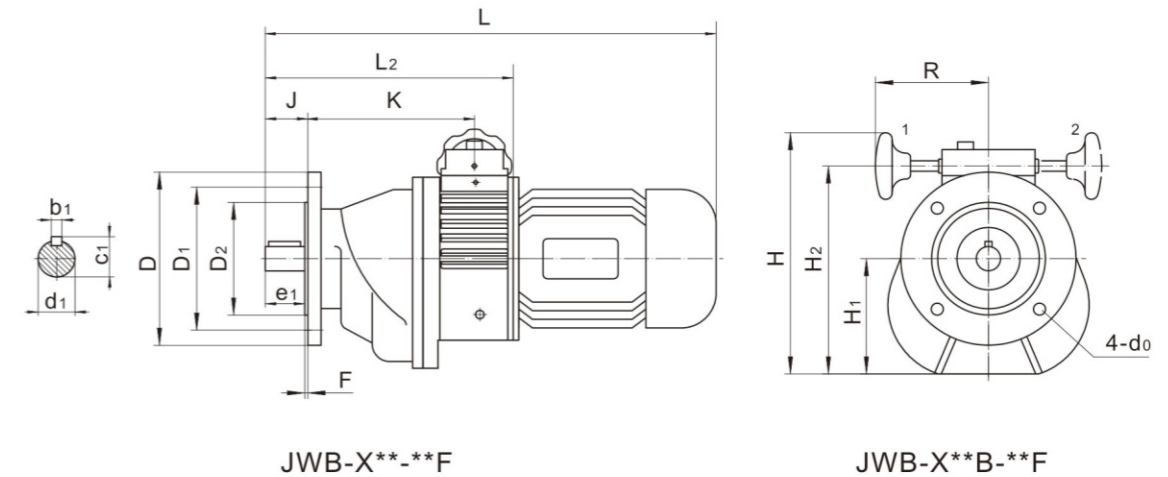
三级齿轮减速(2-4.7D/F)参数/尺寸
 Technical characteristics & dimensions for three-stage gear reducer

型号 Model	机座号 Base No.	整体安装尺寸 Mounting dimension					输出轴尺寸 Output shaft dimension			
		D ₁	D ₂	d ₀	J	F	d ₁	b ₁	c ₁	e ₁
JWB-X**-**F	02	130	110	10.5	61	3.5	32f6	10	35	60
	03	165	130	14	70	3.5	38f6	10	41	70
	04	215	180	14.5	80	4	42f6	12	45	80
JWB-X**B-**F	02	130	110	11	61	3.5	32f6	10	35	60
	03	165	130	14	70	3.5	38f6	10	41	70
	04	215	180	14.5	80	4	42f6	12	45	80

型号 Model	机座号 Base No.	外形尺寸 Outline dimensions								净重 N·W (kg)
		H	H ₁	H ₂	L	L ₂	D	K	R	
JWB-X**-**F	02	248	116	205	556	331	150	232	125	33
	03	278	133	240	615	390	200	271	133	60
	04	329	163	290	759	464	250	311	140	85
JWB-X**B-**F	02	248	116	205	560	335	150	232	125	30
	03	278	133	240	618	396	200	271	133	46
	04	329	163	290	761	468	250	311	140	77

润滑油的代用对照
 Comparison for lubrication replacement

ISO	COMPANY	Vg32
星光传动XINGGUANG TRANSMISSION	广州机床研究所	Ub-1,Ub-3
推荐用油RECOMMENDED LUBRICANTS	壳牌SHELL	A.T.F. DEXRON
	埃索ESSO	A.T.F. DEXRON, TORQUE FLUID N45
	美孚MOBIL	A.T.F. 220,DTE24, Mobilfluid125
	嘉实多CASTROL	TQ.DEXRON II
	英国石油BP	AUTRAN DX,Energol1 HL-XP32
	艾比IP	A.T.F. DEXRON FLUID
	意大利石油AGIP	BLASIA32

注油量(单位:ml) Fill oil quantity(unit:ml)

机座号 Base No.	01	02	03	04	05	06
卧式 Horizontal	150	250	350	700	1500	2800
立式 Vertical F2	-	300	450	900	2300	4400
立式 Vertical F3	-	400	600	1100	2500	4400

一般故障及排除方法 Failure and solution

故障类型Failure	故障原因Reasons	排除方法Solutions
机温过高 Overheating	负荷超载 润滑油不够 润滑油不良 油量过多 Overload insufficient oil Inferior oil Excessive oil	调整负荷或选大机型 加够润滑油 更换润滑油 减少油量 Adjust load or select larger size Fill in adequate oil Fill in proper oil Reduce oil
变速器杂音 Noise	齿轮、齿轴啮合不良 轴承损坏或间隙太大 润滑油不够 异物进入机内 Poor fit between gear and gear shaft Bearing damaged or clearancetoo large Insufficient oil Invadedby foreign objects	修整齿轮齿面 更换轴承 加够润滑油 去除异物或换油 Optimize the surfaces and gears Replace bearing Fill in adequate lubricant Remove foreign objects and replace oil
速度无法调节 Failed to adjust speed	摩擦轮磨损 调速凸轮或底环损坏 主动轮或压环损坏 Planet wheel wore out speed control cam Or fixed-ring damageddriver or Press-ring damaged	修复或更换摩擦轮 修复或更换调速凸轮或底环 修复或更换主动轮或压环 Mending or replace planet wheel Mending or replace speed control cam or fixed-ring Mending or replace driver or press-ring
电机转面输出不转 Motor running but output shaft don'trun	支架损坏 输出轴键损坏 输出轴轴挡损坏 电机键损坏 Carrier damaged Key of output shaft damaged Circlip of output shaft damaged Key of motor damaged	更换支架 更换输出轴键 更换轴挡 更换电机键 Replace carrier Replace key of output shaft Replace circlip of output shaft Replace key of motor
漏油 Oil leakage	油封损伤 密封垫损伤 油量过多 油塞松动 油镜损坏 Oil seal damaged Gasket damaged Excess oil Oil plug loosen Oil-level plug damaged	更换油封 更换密封垫 调整油量 拧紧油塞 更换油镜 Replace oil seal Replace gasket Adjust quantity of oil Tighten oil plug Replace oil level plug